



Download Center ATMOZEN APP

MI-Series Microinverter Quick Installation Guide

Applicable models: MI-600 (MC4)

Atmoce System Introduction

Atmoce microinverters are compact and efficient devices for home power distribution systems. The grid-connected microinverter converts the DC output of a PV module into an AC grid. With the peak efficiency of up to 97.4 % and the MPPT efficiency of up to 99.9 %, Atmoce microinverters ensure maximum utilization of solar energy. Atmoce microinverters are compatible with various PV modules, providing flexible application in different scenarios, like roof and balcony. The Atmoce microinverter system helps homeowners achieve energy independence.

The system includes the following:

- Microinverter: MI-600, etc.
- M-Combiner
- Grid (distribution panel)
- Atmoce-Cloud & Atmozen app
- Battery (Optional)
- AC EV charger (Optional)
- Heat pump or other residential loads (Optional)

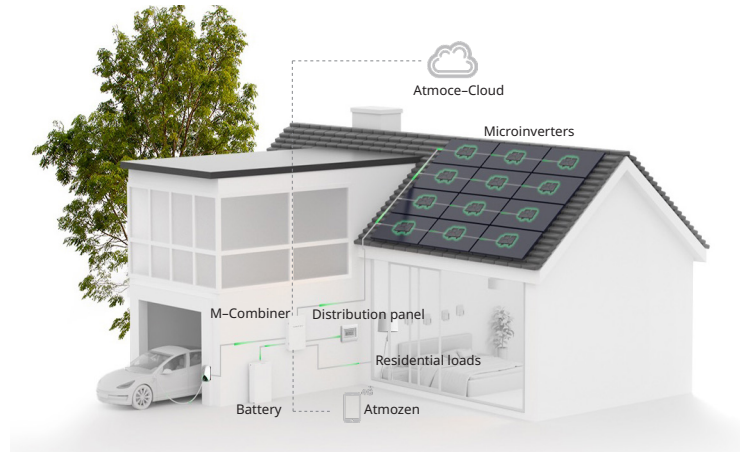

Pre-installation

a. Check the grid voltage

Atmoce microinverter should connect to a single-phase or a three-phase grid. Measure AC line voltages at the point of connection to confirm that they are within the ranges.

Phase setup	Voltage range	
Single-phase	L to N	184 to 276 Vac
Three-phase	L1, L2, L3 to N	184 to 276 Vac

b. Check the electrical compatibility of PV modules

Model	Connector	PV module (cell count)
MI-600	Stäubli MC4	Pair with 54-cell/108 half-cell, 60-cell/120 half-cell, 66-cell/132 half-cell, or 72-cell/144 half-cell

NOTE:

- The maximum open-circuit voltage of PV modules cannot exceed the maximum DC input voltage of Atmoce microinverters. Incompatible PV modules may damage the device and void the warranty.

c. Prepare the tools and materials

Tools: screwdriver, wire stripper, wire crimper, diagonal cutter, torque wrench, electrical drill, marker, etc.

Materials: T-shaped screws and nuts (M8), cold-press terminal, tie wrap, wago connector, etc.

d. Select M-Cable models

When planning the system, it is necessary to select appropriate cables. Atmoce provides the following cable models:

Model	Description	Scenario
MW-025013-A	Three-terminal AC cable, 1.3 m, 2.5 mm ² copper conductor	Mount PV modules in portrait
MW-025023-A	Three-terminal AC cable, 2.3 m, 2.5 mm ² copper conductor	Mount PV modules in landscape
MW-025020-B0	Two-terminal AC cable, 2 m, 2.5 mm ² copper conductor	AC extension cable

e. Prepare the accessories

The following accessories are required, some of which can be found in the package.

Model	Description	Scenario	Provided
MA-001	Disconnect tool	Used to disconnect the connectors of DC and AC cables	Microinverter package
MA-002	AC cable sealing caps	Used to cover the unused connectors	Combiner package
MA-003	Installation map	Used to record the SN and installation position of microinverters	Microinverter package
/	AC junction box	Used to connect the AC cables from the PV AC branch to M-Combiner	Installer
/	T-shaped screws and nuts	Used to mount the microinverters on the PV racking system	Installer

f. Plan the number of microinverters on each PV AC branch

The number of microinverters on each PV AC branch should not exceed the following limits respectively:

Model	Max microinverters/20A branch*	Max microinverters/25A branch*
MI-600	6	8

* Output overcurrent protection is provided by the type C circuit breaker inside the M-Combiner with a rating of 20 A or 25A for MI-600.

Installation

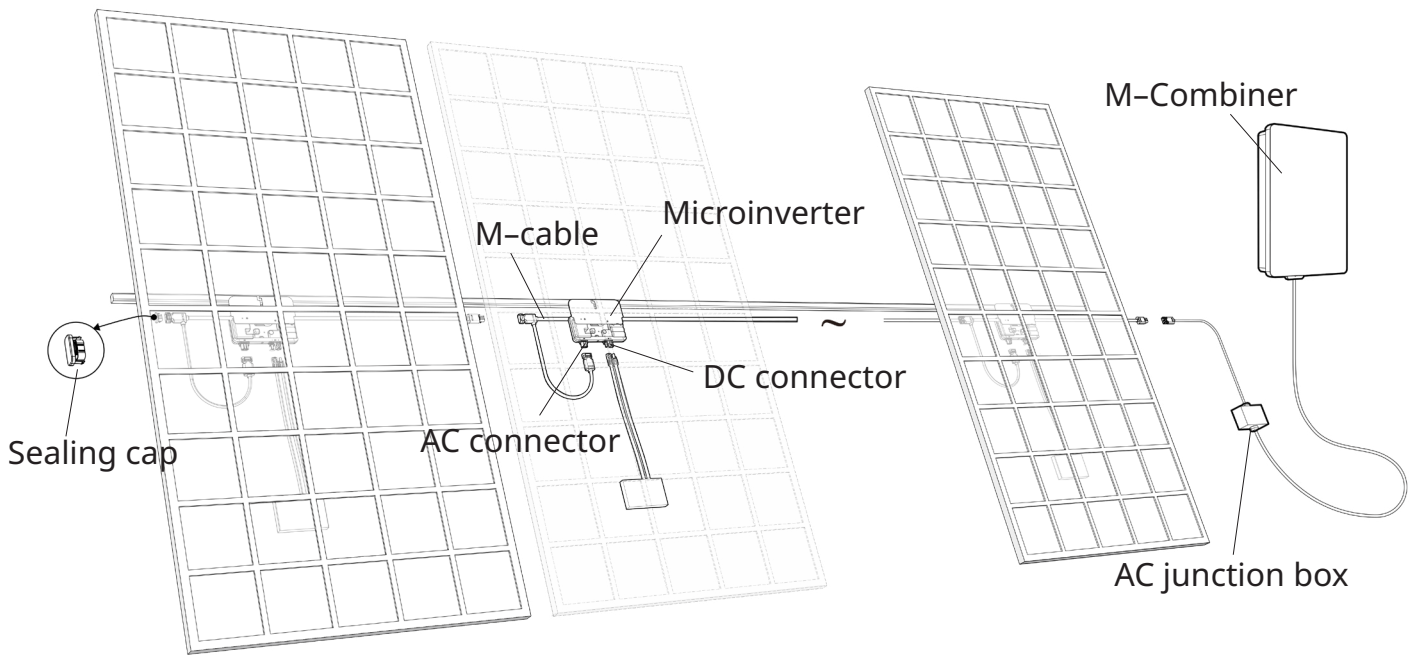

1. Mount the microinverters

- Plan the installation location of the microinverters after installing the PV racking system. It is recommended to install microinverters at the approximate center position of the PV modules.
- Use T-shaped screws to mount the mounting plate of the microinverter onto the PV rack, as shown in the figure.
- When mounting the microinverter, the torque must be maintained within 9–14 N·m (M8 screw).

NOTE:

- Microinverters should not be directly exposed to rain, sun, ultraviolet rays, or other harmful weather conditions.

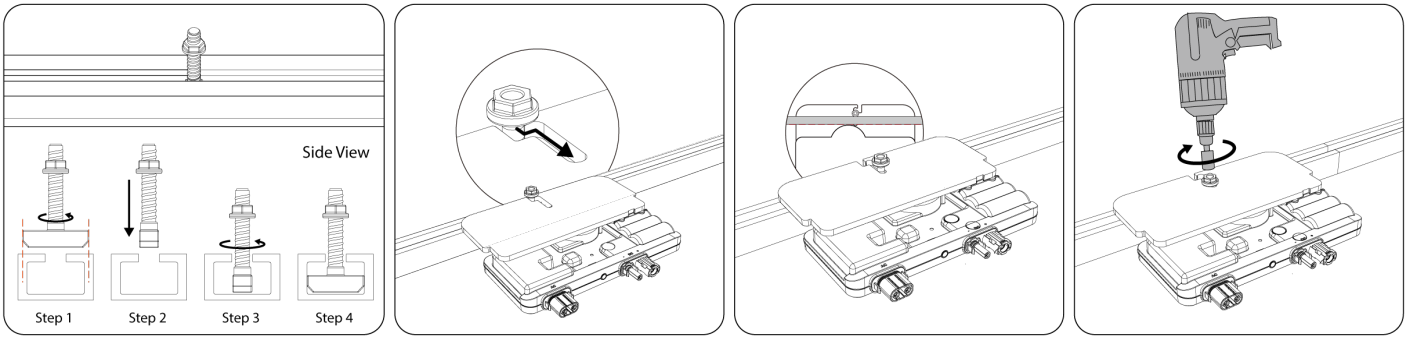

2. Connect the AC output of the microinverters

- Locate the M-cables along the PV rack system.
- Connect Terminal TC to the AC connector of the microinverter, and connect Terminal TB to Terminal TA of the next cable. When any two connectors are successfully connected, a "click" sound can be heard.
- If the distance between two microinverters is relatively far, consider using MW-025020-B0 to extend the cable.

NOTE:

- To disconnect the connectors, a disconnect tool must be used to avoid damaging the device and voiding the warranty. Please refer to "MI-Series Microinverter User Manual" for detailed instructions.

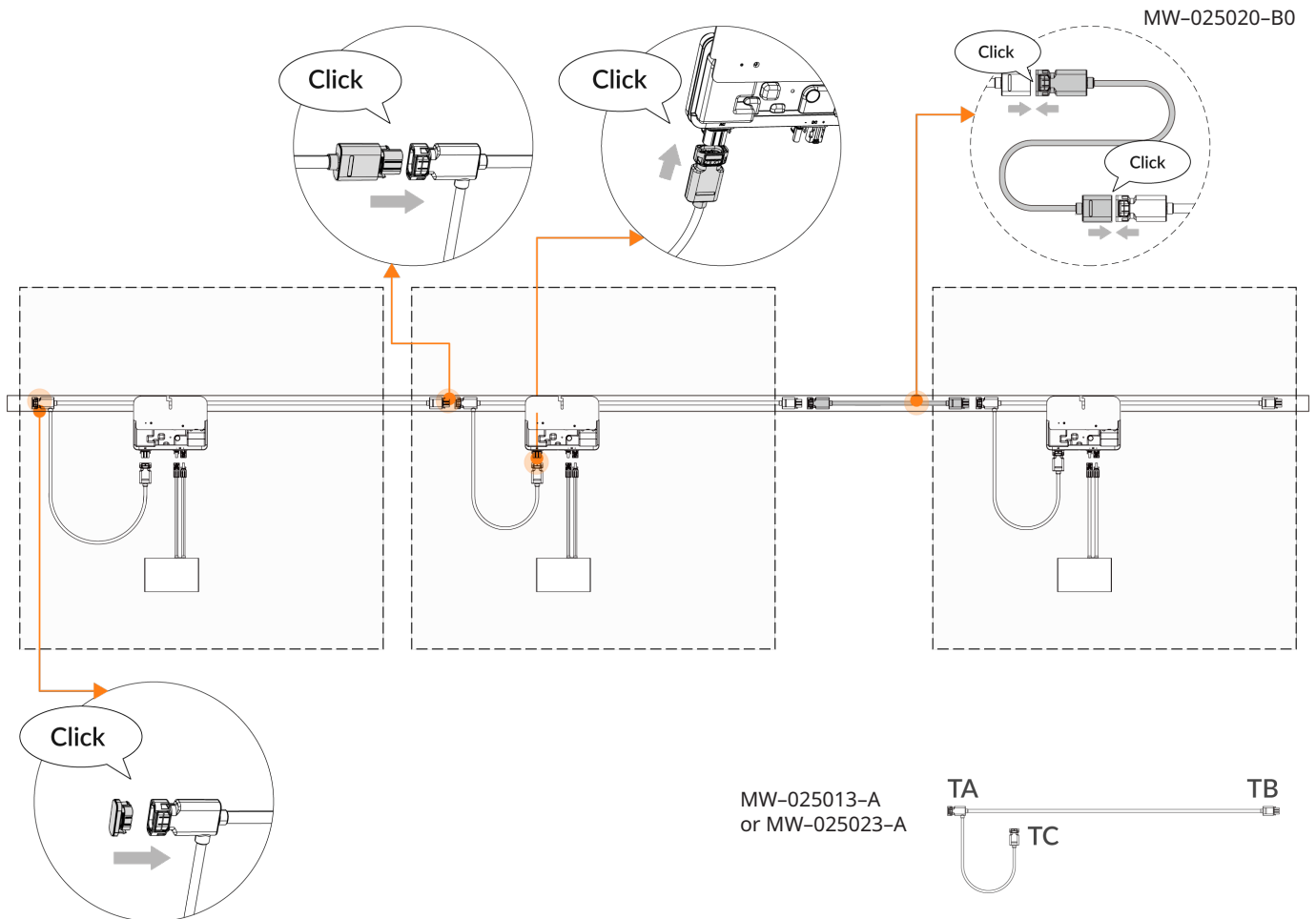

3. Cover the unused end of the cables

- Use the sealing cap to cover any unused AC connectors at the end of the AC cable. When the sealing cap is completely covered, a "click" sound can be heard.

NOTE:

- All unused AC connectors need to be covered with sealing caps to avoid risks such as short circuits when the AC branch is energized.

4. Connect to the AC junction box

- Use the wire stripper to cut off the AC connector at the end of the PV AC branch.
- Remove approximately 25 mm of the cable sheath, and peel off approximately 12 mm of the insulation layer from the L and N wires.
- Connect the AC cable into the AC junction box and crimp the cables as shown below.
- Mount the AC junction box in a suitable position, such as on a roof or wall.
- Close the lid of the AC junction box.

NOTE:

- It is recommended to use a waterproof AC junction box.
- When crimping cables, do not expose the copper conductor to avoid the risk of short circuits.

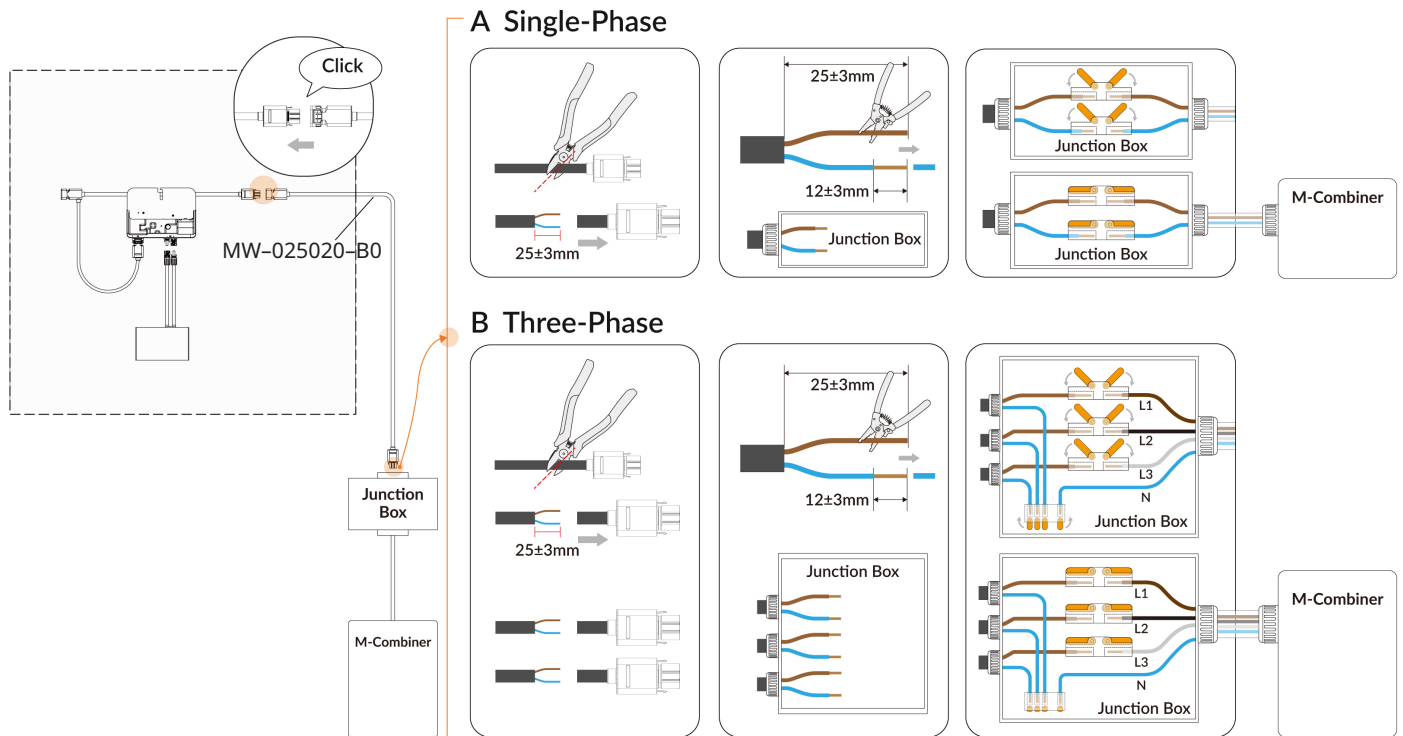

5. Arrange the cables

- Use cable clips or tie wraps to attach the cables to the PV rack.
- The cables should be supported at least every 1 meter.
- Bundle and secure excess cables to prevent cables or connectors from touching the roof.

NOTE:

- Tie wrap should not be directly exposed to the sunlight.

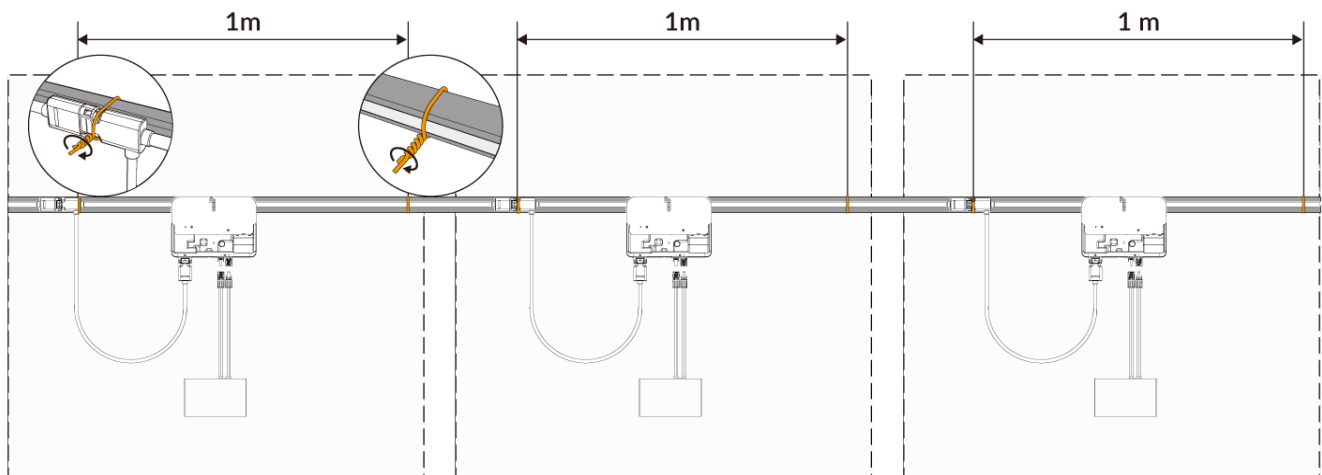

6. Create the installation map

- Take out the paper installation map in the package and use it to record the serial numbers of the microinverters and their positions in the PV array.
- Peel off the detachable serial number label (QR code) from the mounting tab of each microinverter and affix it in the corresponding position onto the paper installation map.

NOTE:

- Please save the paper installation map properly. Input the layout details into the Atmozen app to record the serial numbers and configure the system accordingly.

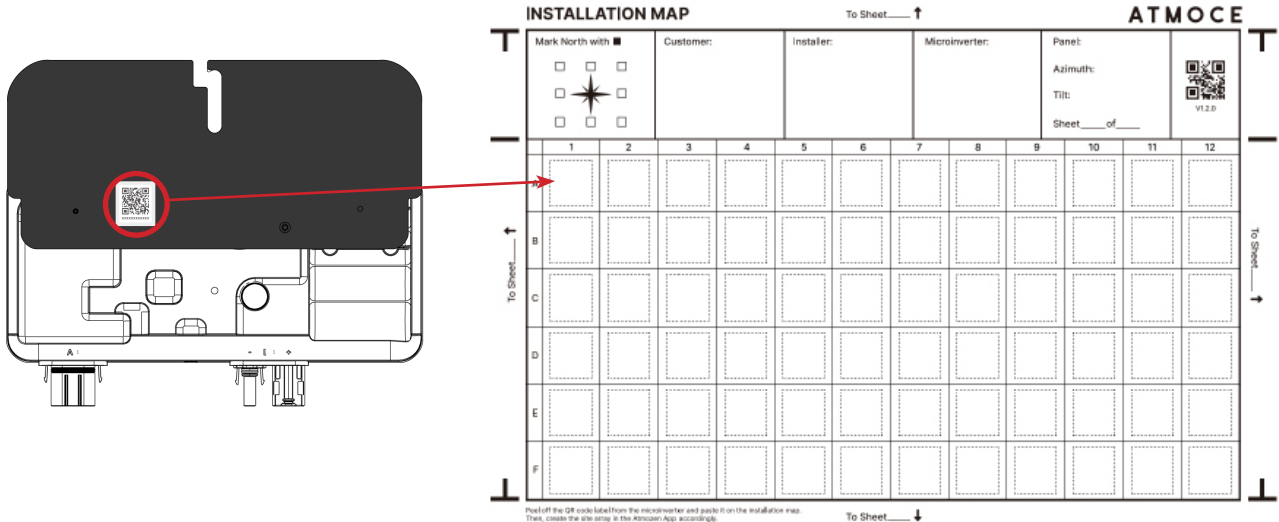

7. Connect the PV modules

- Connect the PV module connectors to the microinverter DC connectors. When any two connectors are successfully connected, a "click" sound can be heard.
- Check the LED indicator on the microinverter. If the LED is on, the microinverter is successfully connected to the PV module.
- Mount the PV modules on the PV rack.

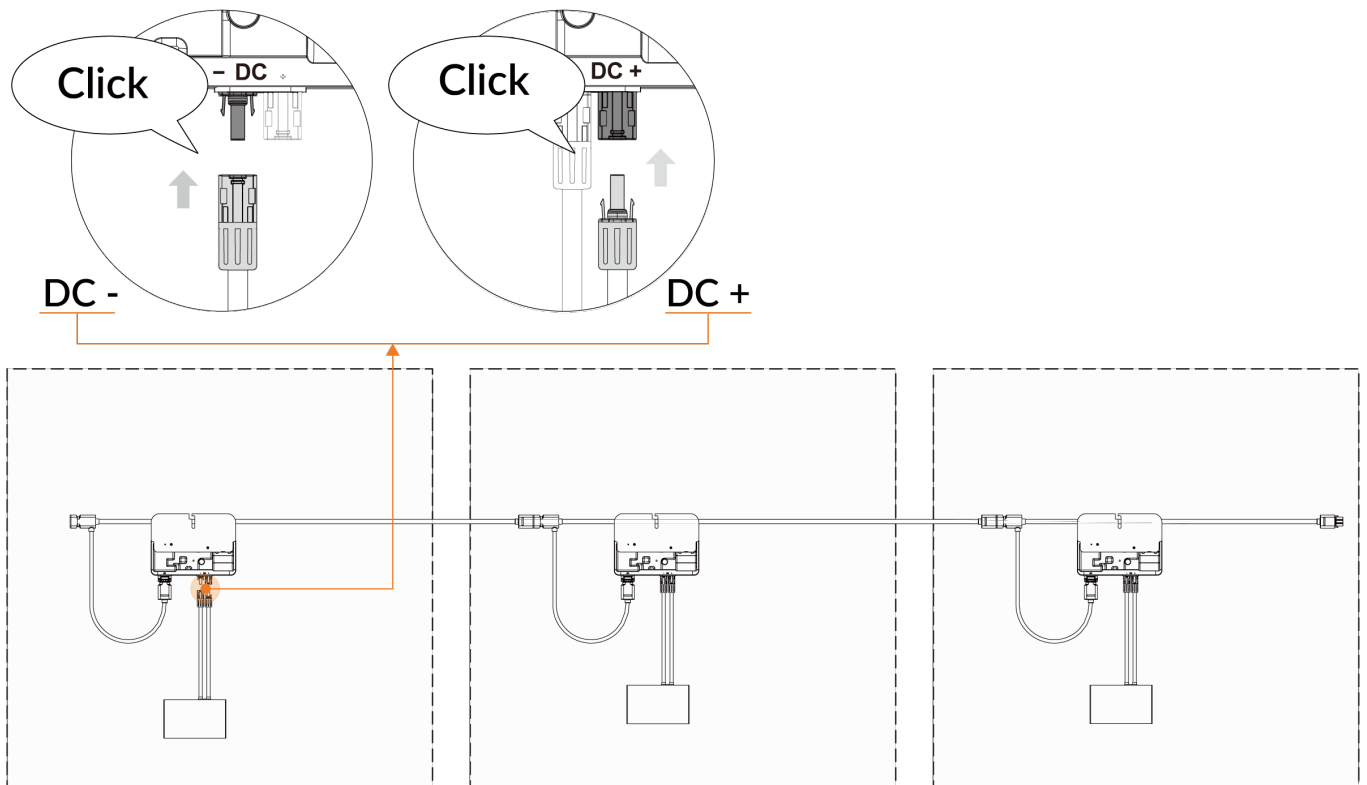

8. Activate the system

- Please refer to "MC100/MC100L/MC100-T Quick Installation Guide/User Manual" to complete the activation.





NOTE:

- Before installing M-Combiner and activating the system, the microinverters will not output AC power.

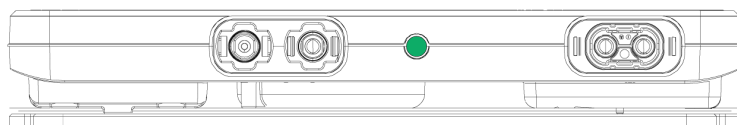
LED indicator description

- Each microinverter has an LED as shown below. The LED provides key information about the operation status. The status of LED helps troubleshoot related issues during on-site installation and configuration.
- The following table describes the status of LED indicator:



-  Solid ON
-  Quick flash:
0.2s ON, 0.2s OFF
-  Slow flash:
1s ON, 1s OFF
-  Dim

LED indicator		Description
Green	Slow flash	Normal operation
	Quick flash	The microinverter is starting up
Orange	Quick flash	The microinverter is waiting for upgrade or is upgrading
	Slow flash	The AC grid is abnormal
Red	Quick flash	Abnormal working condition
	Solid	The microinverter has an internal fault