

M-Battery

MS-7K-U User Manual

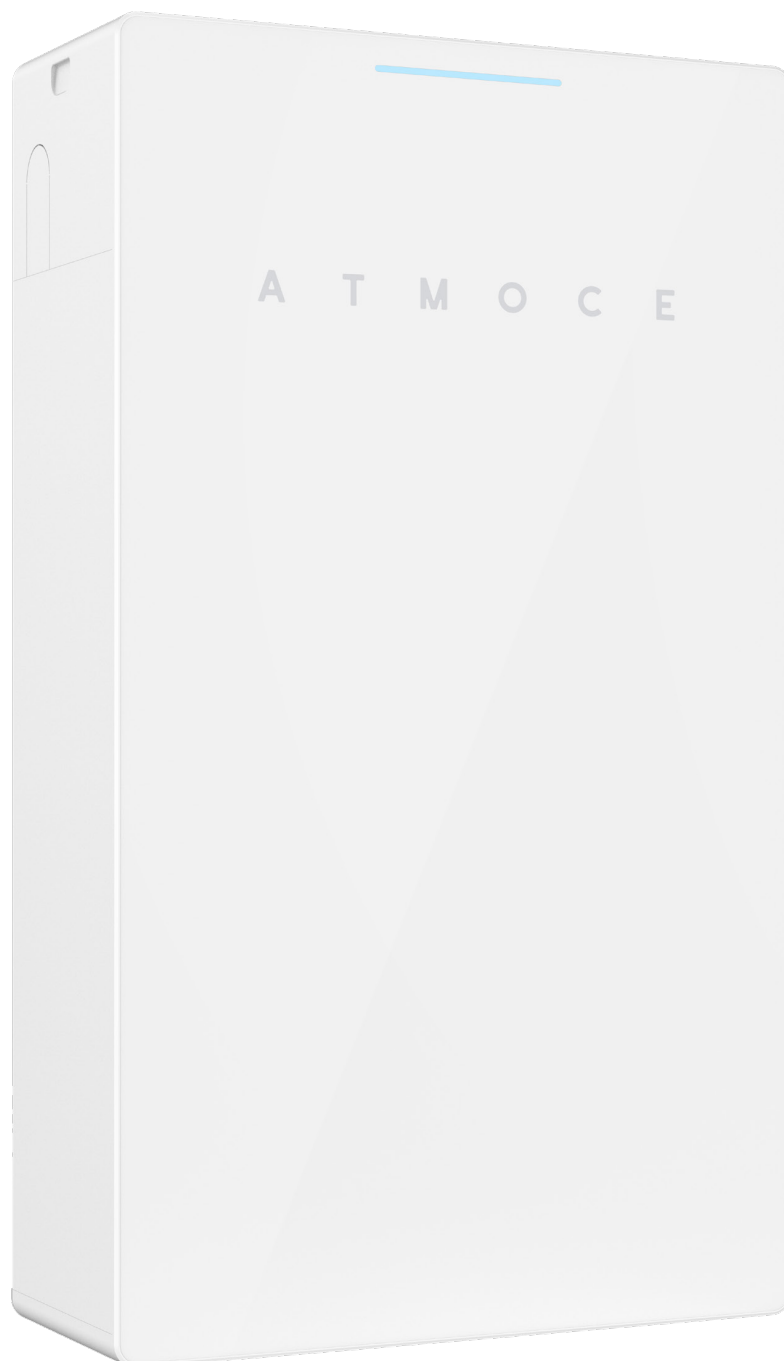

ATMOCE

About This Document

Corporate Contact Information

Company: ATMOCE Holding B.V.

Address: Rokin 92-96, 1012 KZ Amsterdam, the Netherlands

Email: info@atmoce.com

Telephone: +31 20 241 6207

Disclaimer

- Product information is subject to change without prior notice. Every effort has been made in the preparation of this document to ensure accuracy of the content, but all statements, information, and recommendations in this document do not constitute a warranty of any kind, express or implied.
- For optimum reliability and to meet warranty requirements, this product must be installed in accordance with the instructions in this manual.
- For more information about the warranty, visit <https://www.atmoce.com/en/policy/warranty-policy>

Applicable Scope

- This manual is intended for professional installation and maintenance personnel only.
- This manual mainly introduces the assembly, installation, configuration, maintenance, and troubleshooting methods of the following types of battery:
MS-7K-U

Revision History

	Date	Version	Description
1	2025-04-11	Rev. 1.0.0	1. First release.

Contents

About This Document	I
Corporate Contact Information	I
Disclaimer	I
Applicable Scope	I
Revision History	II
Contents	III
Safety Information	1
1.1 Statement	1
1.2 Safety Labels	1
1.3 Personal Safety Instructions	2
1.4 Battery Safety Instructions	3
1.5 Cable Safety Instructions	4
1.6 Environment Instructions	5
Product Information	7
2.1 M-Battery Introduction	7
Storage Requirements	13
Installation	14
4.1 Pre-installation Requirements	14
4.2 Take out the M-Battery	18
4.3 Mount the M-Battery	18
4.4 Remove the Cover of the Wiring Cabinet	22
4.5 Remove the Knockout	23
4.6 Wire the Cables	24
4.7 Close the Cover of the Wiring Cabinet	28
4.8 Remove the Knockout of the Upper Cover	29
4.9 Close the Upper Cover	29

	M-Battery User Manual	
4.10 Power on the System		29
4.11 Activate the System		29
Operation and Maintenance		30
5.1 Battery Working Mode		30
Troubleshooting		31
6.1 LED Indicator Description		31
6.2 Check the Alert Codes		32
6.3 Alert Codes List		33
Technical Data		38
7.1 M-Battery Data Sheet		38
Appendix 1: Terms and Abbreviations		40

Safety Information

1.1 Statement

- Before installing or using the M-Battery, please carefully read the user manual, all instructions, safety labels on the product, and any available safety manuals. Failure to follow these safety instructions may result in personal injury, damage to the equipment, or invalidation of the warranty.
- DANGER, WARNING, CAUTION, and NOTE in this manual must be adhered to. You must also comply with relevant international, national, or regional standards and industry practices. M-Battery assumes no responsibility for any violation of safe operation requirements or safety standards regarding the design, manufacture, and use of the equipment.
- This equipment should only be used in environments that meet its design specifications; any failure, abnormal operation, or damage to components arising from non-compliance will not be covered by the warranty.
- All operations including transportation, storage, installation, operation, use, maintenance, etc., should comply with applicable laws, regulations, standards, and specifications.

1.2 Safety Labels

To reduce the risk of electric shock and ensure the safe installation and operation of the M-Battery system, the following safety symbols are used throughout this manual to indicate hazardous conditions and important safety instructions:

 **Danger** A label indicates a hazard with a high level of risk. Failure to avoid this hazard may result in serious personal injury or death.

 **Warning** A label indicates a hazard with a medium level of risk. Failure to avoid this hazard may result in serious personal injury or death.

 **Caution** A label indicates a hazard with a low level of risk. Failure to avoid this hazard may result in serious personal injury or death.

 **Note** A label indicates a safety hazard or risk of device damage. Failure to avoid this hazard may result in equipment damage, data loss, reduced performance, or other consequences, but does not involve personal injury.

1.3 Personal Safety Instructions



Danger

- **No live electrical work:** The installation process must never be performed with live electricity. It is prohibited to install or remove cables while the system is energized. If the cable core comes into contact with the conductor, it can cause electric arcs or sparks, which can lead to fire or personal injury.
- **Risk of Fire or Electric Shock:** When the equipment is powered on, improper or unregulated operation can result in fire, electric shock, or explosion, potentially causing injury, death, or property damage.
- **Work with Assistance:** Always have someone nearby when working with electrical equipment. They should be within earshot or close enough to assist in case of emergency. Remove any metal jewelry (rings, bracelets, necklaces, watches) when working with the M-Battery or any electrical components.
- **Power Off Before Installation:** Do not apply power to the equipment until installation is fully completed and verified by a qualified person.



Warning

- **Use Personal Protective Equipment (PPE):** Ensure that all workers use appropriate protective gear, such as protective clothing, insulated footwear, goggles, helmets, and insulated gloves, during installation or maintenance operations.
- **Adhere to Warnings and Precautions:** Never ignore warnings, cautions, or precautionary measures indicated in the manuals or on the equipment itself.
- **Take Immediate Action in Case of Malfunction:** If any malfunction is detected during operation that could lead to personal injury or equipment damage, immediately stop the operation, report it to the supervisor, and implement the necessary safety measures.



Note

- **Proper Installation by Qualified Personnel Only:** Installation and maintenance must only be performed by trained professionals. M-Battery is not liable for any loss or damage caused by improper use, installation, or misuse of the product.
- **Training Requirements:** Personnel responsible for the installation and maintenance of the M-Battery must undergo proper training to ensure they understand safe operation methods, relevant safety precautions, and local standards and regulations.

1.4 Battery Safety Instructions



Danger

- **Unauthorized Repair Prohibited:** Do not attempt to repair the M-Battery without authorization, as it contains no user-repairable components. Unauthorized disassembly, repair, or destruction of the device will void the warranty. In case of malfunction, please contact Atmoce for technical assistance.
- **Authorized Use Only:** Only use the M-Battery as specified by Atmoce. Unauthorized use may result in equipment damage or personal injury.
- **Use Approved Accessories Only:** Only use accessories approved by Atmoce. The use of unauthorized accessories may cause equipment damage or personal injury.
- **Power Off Before Work:** Since the M-Battery is powered by multiple sources, ensure all circuit breakers are turned off before starting any installation, maintenance, or cleaning work.
- **Do Not Operate If Damaged:** Do not operate the M-Battery if its appearance or internal components are damaged. Ensure the device is intact before use.



Warning

- **Inspect Cables and Connectors:** Regularly inspect cables and connectors to ensure they are in good condition. Do not operate the M-Battery with damaged or non-compliant cables or connectors.
- **Do Not Disassemble the Enclosure:** Do not disassemble the M-Battery enclosure or protective panels unless necessary for maintenance.



Note

- **Compliance with Installation Regulations:** When installing the M-Battery, ensure compliance with all applicable installation standards and local electrical regulations.
- **Temperature Limitations:** The M-Battery is suitable for use in environments with a maximum ambient temperature of 55°C. Ensure the installation environment meets this temperature limit.
- **Use of Suitable Wiring:** When installing the M-Battery, use copper wiring with a temperature resistance of 90°C or higher. Ensure the wiring meets local electrical standards.

- **Cable and Connector Safety:** Choose cables that meet safety requirements based on circuit breaker parameters. Ensure cables and connectors are in good condition and operate within rated specifications.
- **Grid Connection:** Do not connect the M-Battery to the grid or AC circuit until all installation steps are completed and approval has been obtained from the utility company.

1.5 Cable Safety Instructions



Danger

- **Disconnect Power Before Installation:** Do not attempt to install or work with cables unless the circuit is disconnected. Always ensure the power is off before working on any electrical connections.
- **Avoid Damaging the Cable:** Take care not to damage the copper conductor of the cable when stripping the sheath. Damaged wires may result in improper system functionality or failure.



Warning

- **Check AC and DC Wiring:** Ensure that all AC wiring are correct and free of any pinches, shorts, or damage. Verify that all AC junction boxes are properly closed and secured.
- **Ensure Proper Cable Connections:** All cables must be securely connected, well-insulated, and meet the appropriate specifications for the system.



Note

- **Compliance with Local Standards:** Cable selection and routing must comply with local laws, regulations, and industry standards.
- **Respect Cable Bending Radius:** When routing cables, ensure the minimum bending radius is 8x the cable's outer diameter (8xOD).
- **Replace Insufficient Cable Length:** If the power cable length is found to be insufficient, replace it with a properly sized cable. Joints or welding points in the power cable are strictly prohibited.
- **Avoid Tension on Cable Terminal:** Do not expose cable terminals to continuous tension. Avoid pulling or bending the cable at the connection points.
- **Smooth Cable Crossing Holes:** Ensure that cable crossing holes are free of sharp edges to prevent damage from burrs or other sharp objects.

- **Keep the Wire Cabinet Clean:** Always keep the wire cabinet free from dirt, debris, and contaminants. Prevent dirt or debris from entering the connectors during installation and operation.
- **Compliance with Local Regulations:** Ensure all installations and maintenance comply with national and local electrical regulations.

1.6 Environment Instructions



Danger

- **Avoid Hazardous Environments:** Do not place the M-Battery in environments with flammable or explosive gases, vapors, or fumes. Never perform any operations in such environments.
- **Explosion Risk:** Do not install or use the M-Battery in a potentially explosive environment. Ensure the equipment is not exposed to conditions that could lead to combustion or detonation.
- **Heat and Ignition Sources:** Avoid placing the equipment near heat sources, such as fireworks, candles, heaters, or other devices that generate heat. The heat produced by the equipment may cause damage or create a fire hazard.
- **Avoid Direct Sunlight Exposure:** Do not expose terminals or connectors to direct sunlight, as this may lead to overheating or degradation of materials.



Warning

- **Weather Conditions:** Do not attempt to install or use the M-Battery in adverse weather conditions, including rain, snow, or extreme temperatures. Ensure the equipment is installed in dry, stable conditions.
- **Protect from Pressurized Liquids:** Do not expose terminals or connectors to directed pressurized liquids (e.g., water jets). Ensure the equipment is shielded from water or other liquids.
- **Avoid Immersion in Liquids:** Never immerse the terminals, connectors, or any part of the M-Battery in liquid, as this could cause malfunction or permanent damage.
- **Corrosive and Volatile Environments:** Do not install the M-Battery in areas with volatile gases, corrosive substances, or organic solvents. Such environments could degrade the equipment or create safety hazards.

- **Avoid Harsh Environmental Factors:** Do not install the M-Battery in areas subject to strong vibrations, excessive noise, or strong electromagnetic field interference.
- **Sturdy Mounting Surface:** Ensure that the mounting surface for the M-Battery is stable and capable of bearing the equipment's weight. Proper installation on a secure surface prevents equipment malfunction or damage.
- **Remove Packing Materials:** After installation, ensure that all packaging materials such as cardboard boxes, foam, plastic, and cable ties are removed from the equipment area to maintain a clean and safe environment.

Product Information

2.1 M-Battery Introduction

2.1.1 Overview

The ATMOCE MS-7K-U battery is a fully integrated system with a usable energy capacity of 7.0 kWh. It supports both single-phase and three-phase grid systems, offering self-consumption, TOU and grid ancillary services modes that enables homeowners to achieve energy independence by generating and utilizing their energy while participating in grid services.

2.1.2 Structure dimension

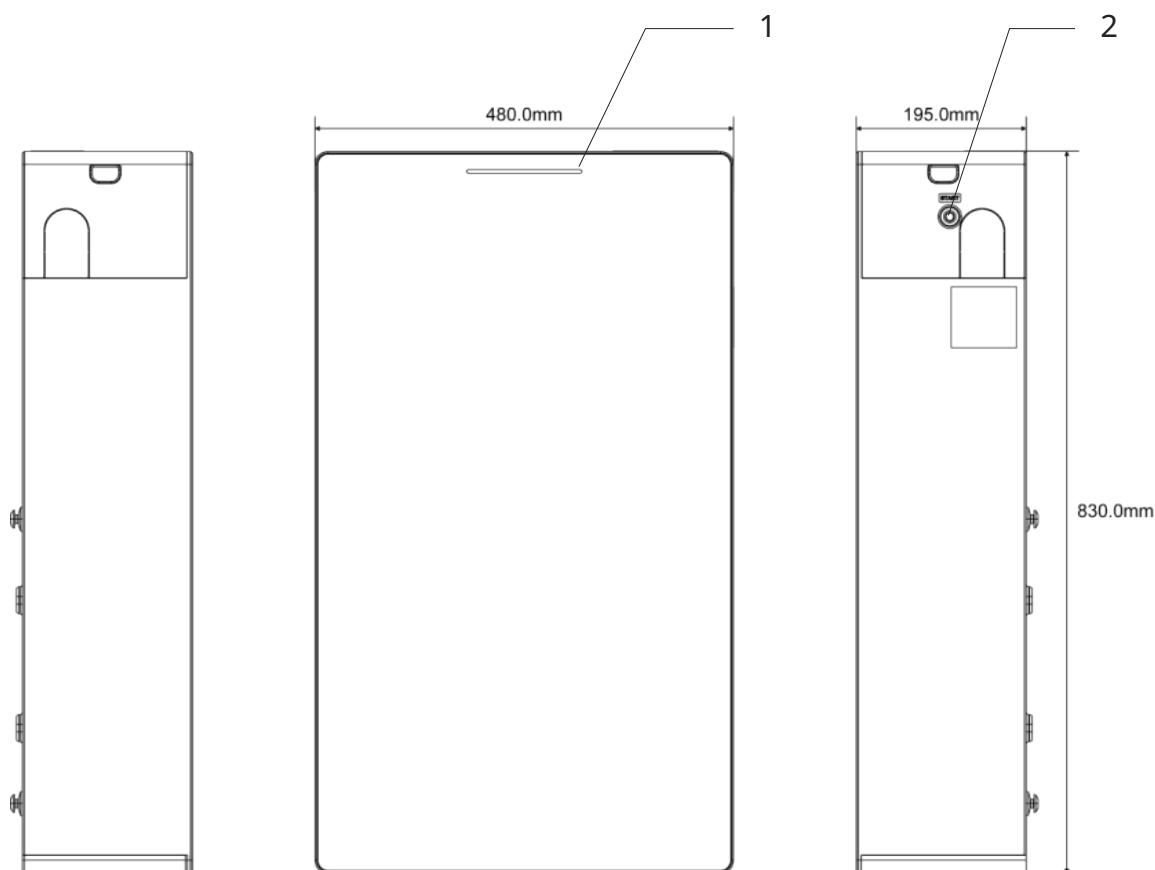

1. LED indicator
2. Reset button

2.1.3 Battery structure introduction

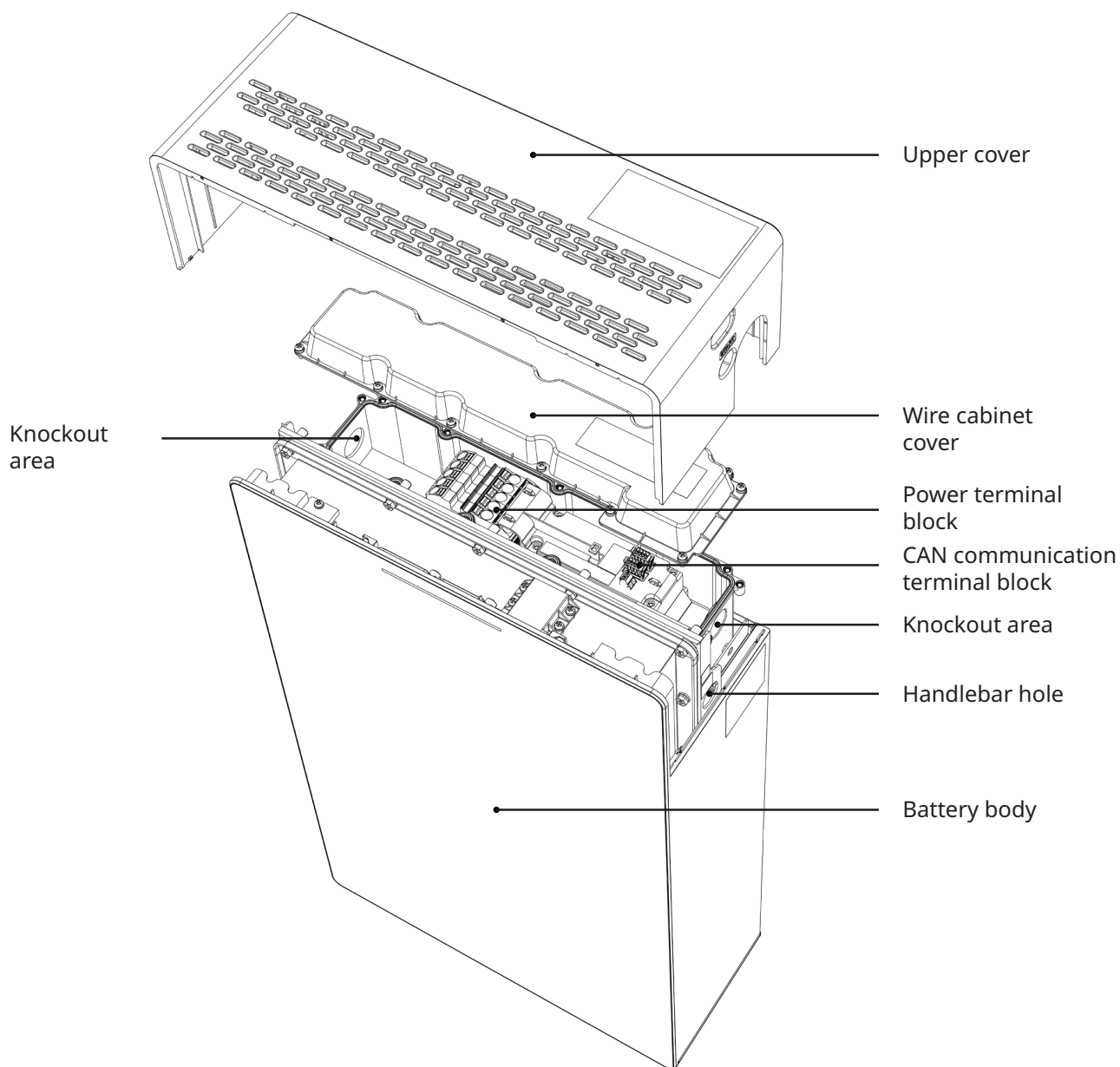

2.1.4 Label introduction

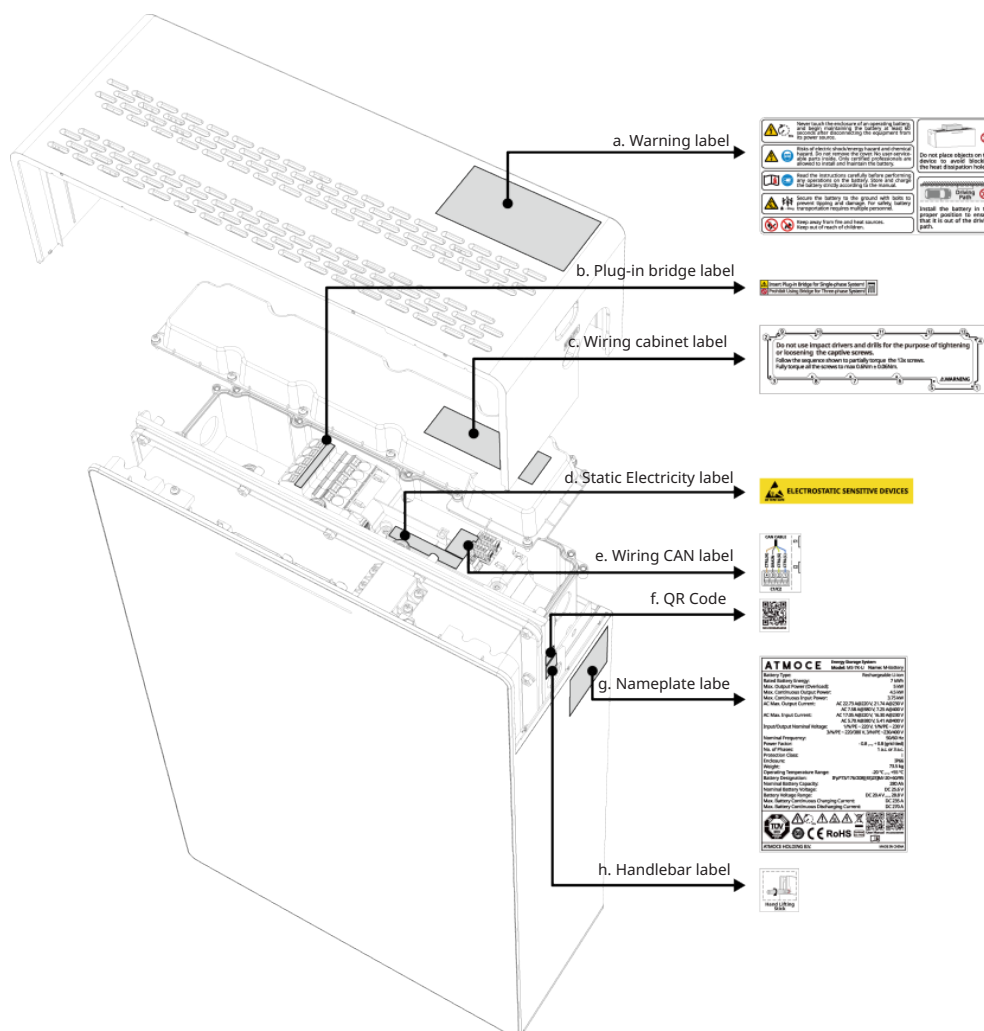

a. Warning label

	Never touch the enclosure of an operating battery, and begin maintaining the battery at least 60 seconds after disconnecting the equipment from its power source.		Do not place objects on the device to avoid blocking the heat dissipation hole.
	Risks of electric shock/energy hazard and chemical hazard. Do not remove the cover. No user-serviceable parts inside. Only certified professionals are allowed to install and maintain the battery.		Install the battery in the proper position to ensure that it is out of the driving path.
	Read the instructions carefully before performing any operations on the battery. Store and charge the battery strictly according to the manual.		
	Secure the battery to the ground with bolts to prevent tipping and damage. For safety, battery transportation requires multiple personnel.		
	Keep away from fire and heat sources. Keep out of reach of children.		

b. Plug-in bridge label



c. Wiring cabinet label

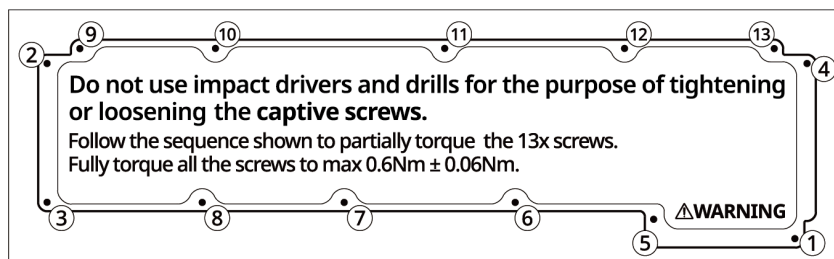

d. Static electricity label



e. Wiring CAN label

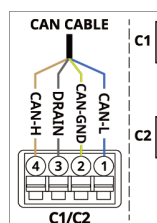

f. QR code



g. Nameplate



ATMOCE Energy Storage System	
Model: MS-7K-U	Name: M-Battery
Battery Type:	Rechargeable Li-ion
Rated Battery Energy:	7 kWh
Max. Output Power (Overload):	5 kW
Max. Continuous Output Power:	4.5 kW
Max. Continuous Input Power:	3.75 kW
AC Max. Output Current:	AC 22.73 A@220 V, 21.74 A@230 V
	AC 7.58 A@380 V, 7.25 A@400 V
AC Max. Input Current:	AC 17.05 A@220 V, 16.30 A@230 V
	AC 5.70 A@380 V, 5.41 A@400 V
Input/Output Nominal Voltage:	1/N/PE ~ 220 V, 1/N/PE ~ 230 V
	3/N/PE ~ 220/380 V, 3/N/PE ~ 230/400 V
Nominal Frequency:	50/60 Hz
Power Factor:	- 0.8 ,,,, + 0.8 (grid tied)
No. of Phases:	1 a.c. or 3 a.c.
Protection Class:	
Enclosure:	IP66
Weight:	73.5 kg
Operating Temperature Range:	-20 °C ,,,, +55 °C
Battery Designation:	IFpP73/176/208[(4S)2S]M/-20+60/95
Nominal Battery Capacity:	280 Ah
Nominal Battery Voltage:	DC 25,6 V
Battery Voltage Range:	DC 20.4 V ,,,, 28.8 V
Max. Battery Continuous Charging Current:	DC 235 A
Max. Battery Continuous Discharging Current:	DC 270 A

User Manual
 SN:EH0000000

ATMOCE HOLDING B.V. MADE IN CHINA

Nameplate Label Instruction

Lable	Description
	The product has passed CE related certification.
	Waste electrical and electronic equipment (WEEE), which cannot be treated as household waste and should be returned to ATMOCE or disposed of in accordance with local regulations.
RoHS	Restriction of Hazardous Substances (ROHS)-compliant.
	Please read the user manual before using the equipment.
	Delayed discharge. Wait 60 seconds for the unit to fully discharge after it is powered off.
	Risk of burn. Do not touch the enclosure of the microinverter, as its temperature will become high during operation.
	Risk of electric shock. Switch off the power to the circuit breaker(s) you're working with.

Lable	Description
	Exceeding this period may pollute the environment
	Caution.

h. Hnadlebar label

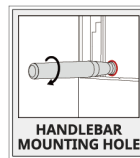

Storage Requirements

If the product is not to be used and installed immediately, it must be stored in accordance with the following requirements:

- Do not remove the outer packaging of the product.
- The storage temperature should be maintained within $-20\text{ }^{\circ}\text{C}$ to $+55\text{ }^{\circ}\text{C}$.
- The relative humidity should be maintained between 4% RH and 100% RH.
- Store the product in a clean and dry place, away from dust and moisture.
- Stack no more than 7 layers high. When stacking, please be careful when placing the packaging box to avoid personal injury or equipment damage caused by equipment tipping over.
- Regular inspections are required during storage (once every three months recommended). If the product has been placed in storage for two years or longer, it must be inspected and tested by qualified personnel before use.
- Regular recharging are required during storage as the table below.

Storage temperature	Storage time
$-20^{\circ}\text{C} < T \leq 25^{\circ}\text{C}$	15 months
$25^{\circ}\text{C} < T \leq 35^{\circ}\text{C}$	9 months
$35^{\circ}\text{C} < T \leq 45^{\circ}\text{C}$	6 months
$45^{\circ}\text{C} < T \leq 55^{\circ}\text{C}$	3 months

NOTE:

- If it is within the storage time, the battery does not need to be recharged.
- If it has exceeded the storage time, the battery should be recharged as soon as possible.
- The maximum number of recharging is 3. If the maximum number of times is exceeded, it is recommended to discard the battery.
- The battery power must be recharged to 30% SOC.

Installation

4.1 Pre-installation Requirements

4.1.1 Grid requirements

ATMOCE battery should connect to a single-phase or a three-phase grid. Measure AC line voltages at the point of connection to confirm that they are within the ranges.

Phase setup	Voltage range	
Single-phase	L to N	184 to 276 Vac
Three-phase	L1, L2, L3 to N	184 to 276 Vac

4.1.2. Cable requirements

To properly set up the system, it is necessary to select the appropriate cables. The table below shows the recommended cable requirements.

Function	Recommendation	
Power cable	6 to 10 mm ² , 5-core(3*L+N+PE)	450/750V, copper core wire with a maximum allowable operating temperature of not less than 90°C
CAN COM cable	0.2 to 0.5 mm ² , 3-core	300V, three-core shielded

NOTE:

- When connecting the cables to the M-Battery, you must cover the cable ends by using the proper cold-press terminal provided in the package.
- When stripping the cable, remove approximately 12 mm of the insulation layer from the power cable and 8 mm of insulation layer from the communication cable.

4.1.3 Prepare the Tools and Materials

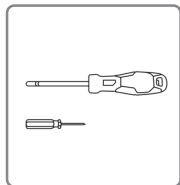

Screwdriver
(M8)

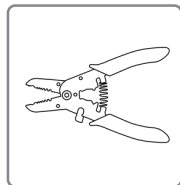

Wire stripper

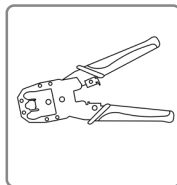

Power line crimper

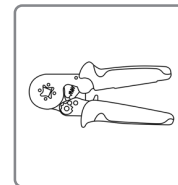

Communication line
crimper

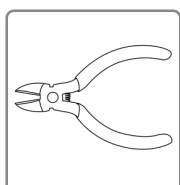

Diagonal cutter

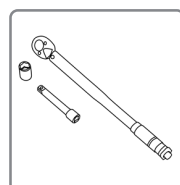

Torque wrench

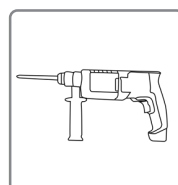

Drill

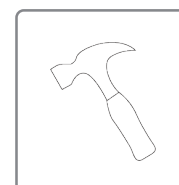

Hammer

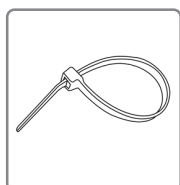

Tie wrap



Multimeter

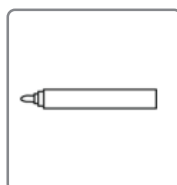

Marking pen

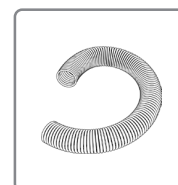

Corrugated protective
pipe

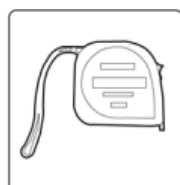

Tape measure

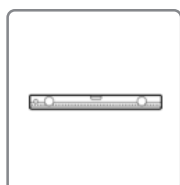

Spirit level

4.1.4 Prepare the Safety Equipment

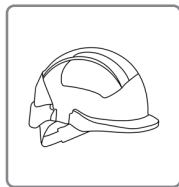

Safety helmet

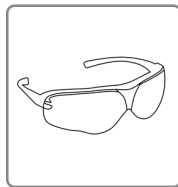

Protective goggles

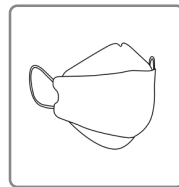

Mask

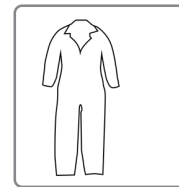

Safety clothing

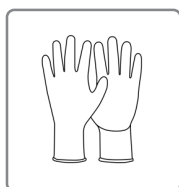

Safety gloves

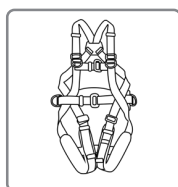

Safety belt



Safety shoes

4.1.5 Download the Atmozen App

Download the latest version of the Atmozen app. Open and log in to your account. You can track the progress of system installation with this app.



4.1.6. Recommended installation environment and space

a. The installation environment should be:

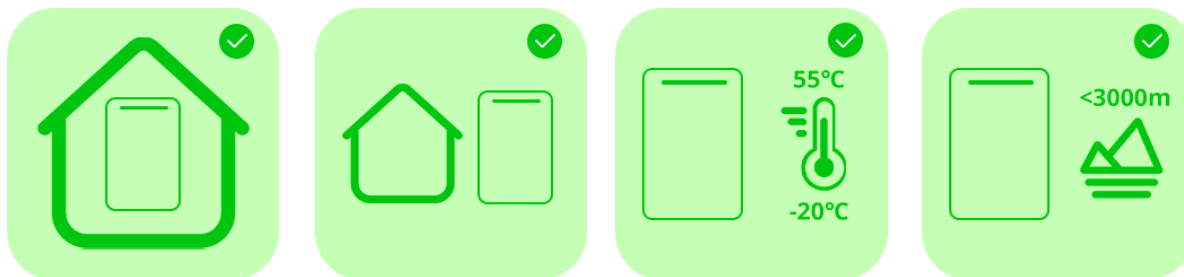

b. The installation environment should not be:

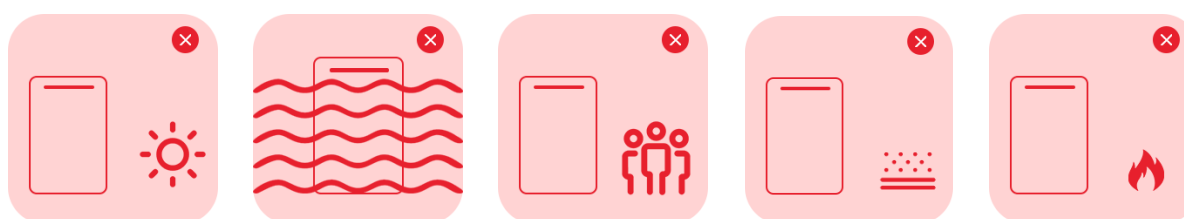

c. The installation space should meet the following conditions.

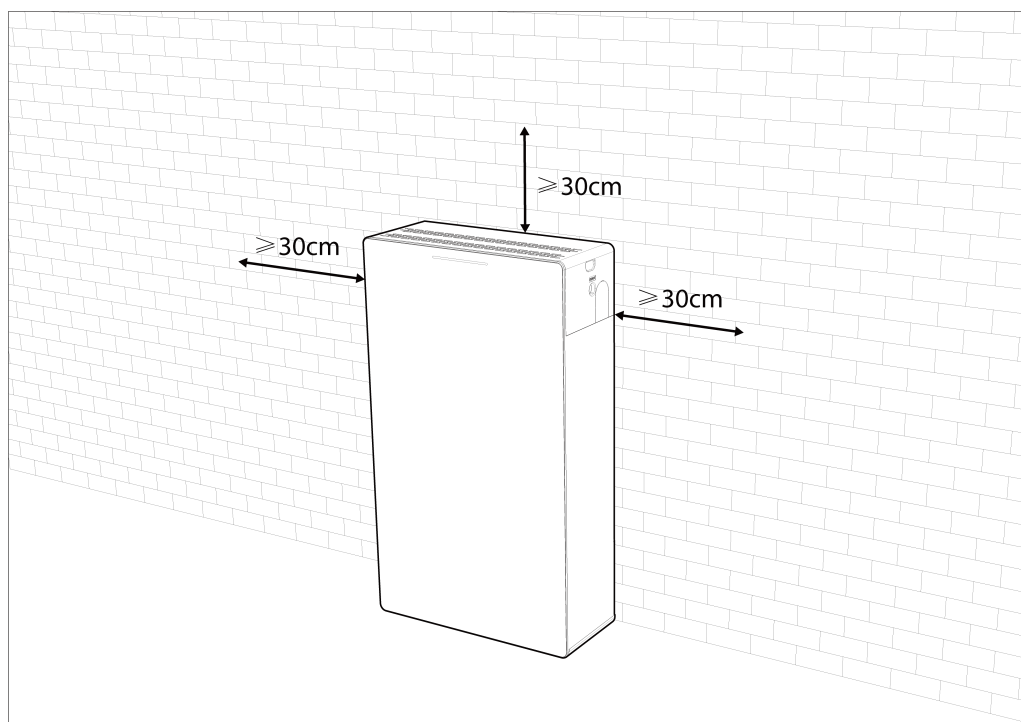

4.2 Take out the M-Battery

a. Check the accessories in the box, it contains the following items.

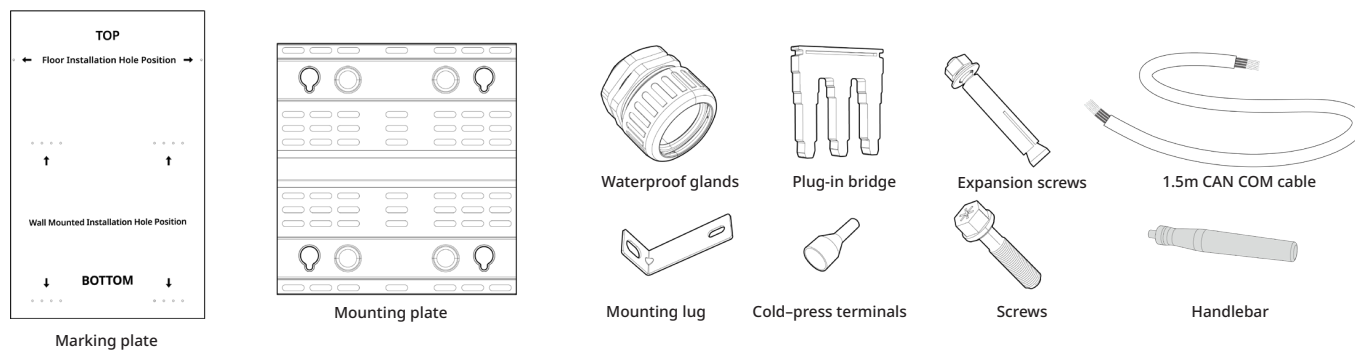

- After unboxing, remove the upper cover of the M-Battery.
- Take out the handlebars and insert them into the holes on the both sides of the battery.
- Remove the battery out of the box.

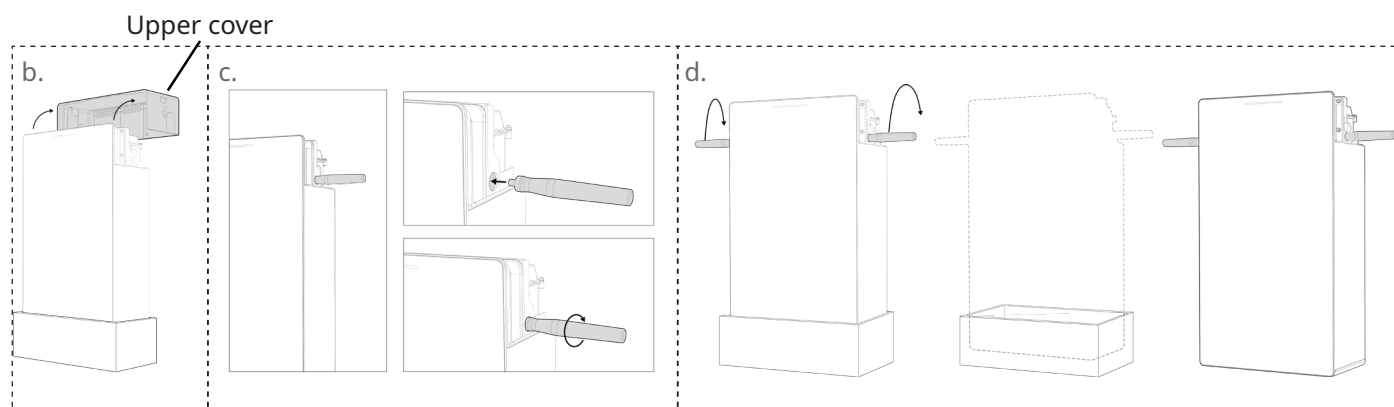

4.3 Mount the M-Battery

For floor installation, the floor must be level, otherwise wall mounting is recommended.

4.3.1 Mount on the floor

- Take out the marking plate and place it on the wall. Use the spirit level to check that the plate is level, then make the marks.
- Drill at the two marks by using an electric drill with a bit ($\Phi 14$).

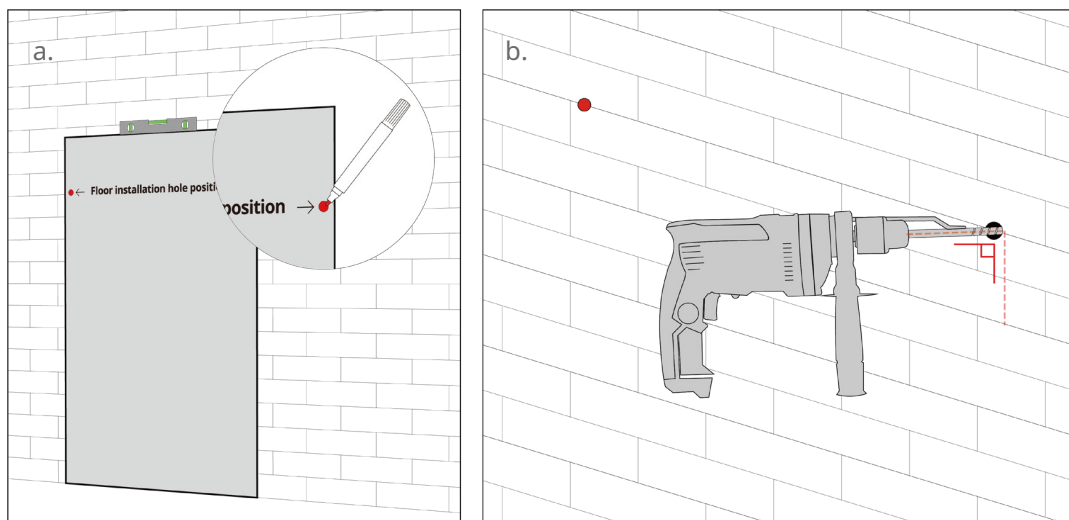

- c. Take out the expansion screws and align them with the holes. Knock them into the wall with a hammer and tighten the screws with a torque of 9–14 N·m, then loosen the screws.

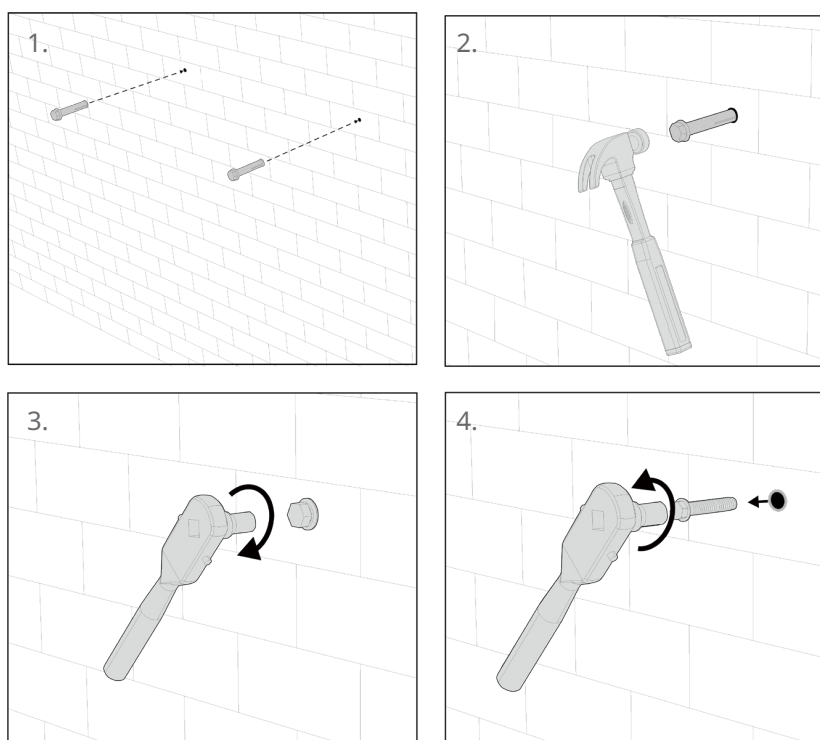

- d. Place the battery close to the wall, ensuring it is parallel to the wall and perpendicular to the floor.

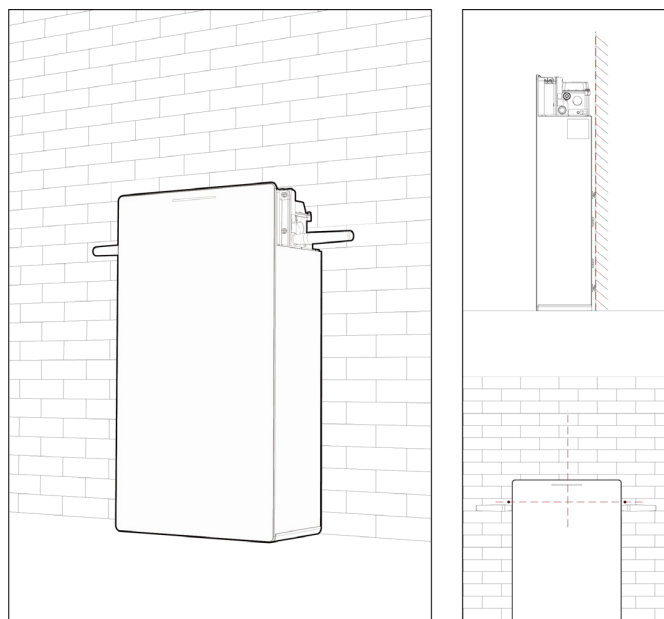

- e. Remove the handlebars and take out the mounting lugs and align them with the holes on the both sides. Insert the M6 screws and tighten the screws with a torque of 3 N·m.

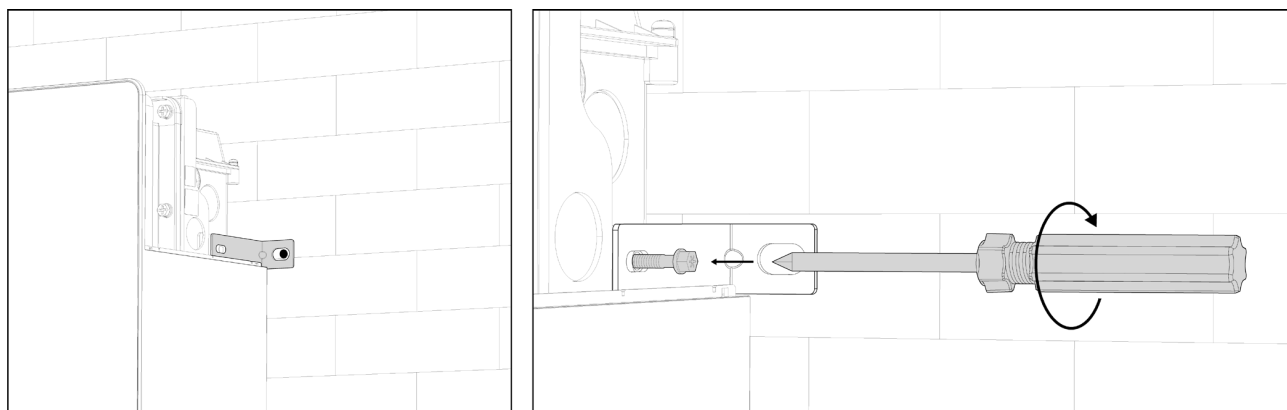

- f. Insert the M10 expansion screws and tighten the screws with a torque of 9–14 N·m.

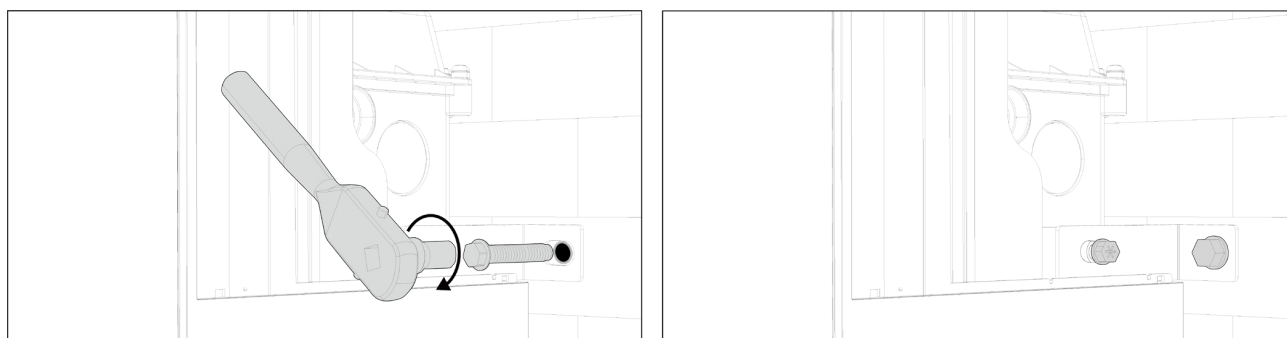

NOTE:

- Please do not tighten the screws completely until confirming that the mounting lugs can be fully installed.

4.3.2 Mount on the wall

- a. Take out the marking plate and place it on the wall. Use the spirit level to check that the plate is level, then make the marks.
- b. Drill at the four marks by using an electric drill with a bit ($\Phi 14$).

NOTE:

- The total weight for M-Battery, including the battery unit, and mounting plate, is 75 kg. The wall shall bear the battery weight.

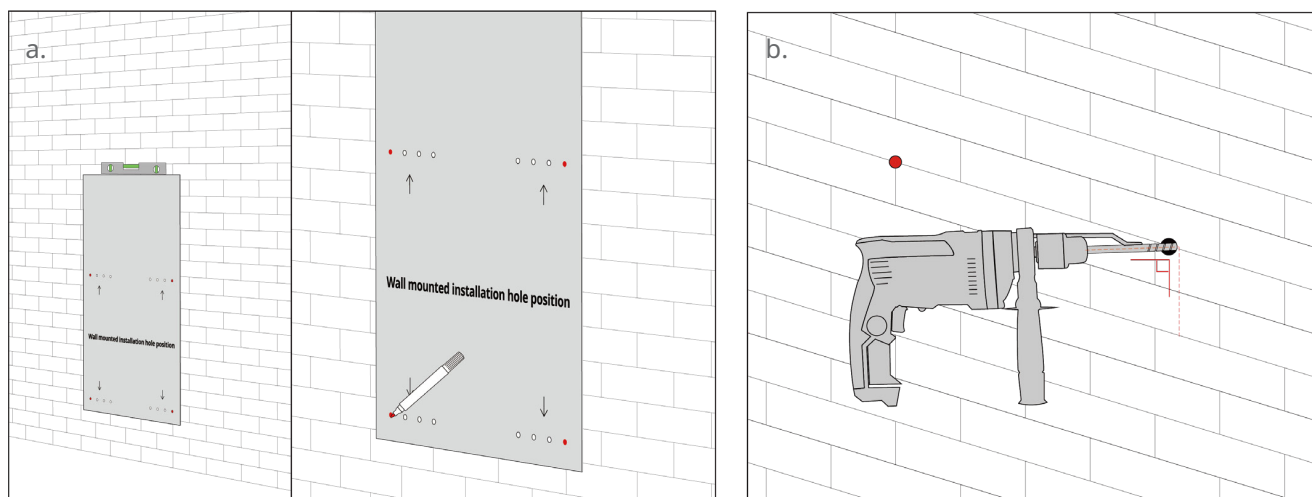

- c. Take out the expansion screws and align them with the holes. Knock them into the wall with a hammer and tighten the screws with a torque of 9–14 N·m, then loosen the screws.

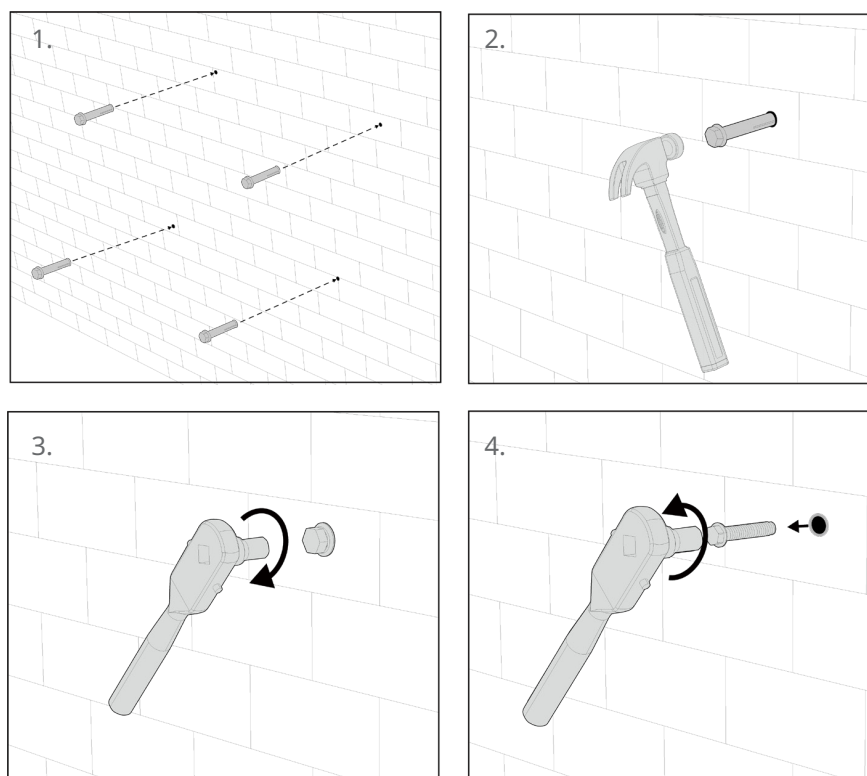

- d. Take out the mounting plate and align it with the holes. Insert and tighten the screws with a torque of 9–14 N·m.

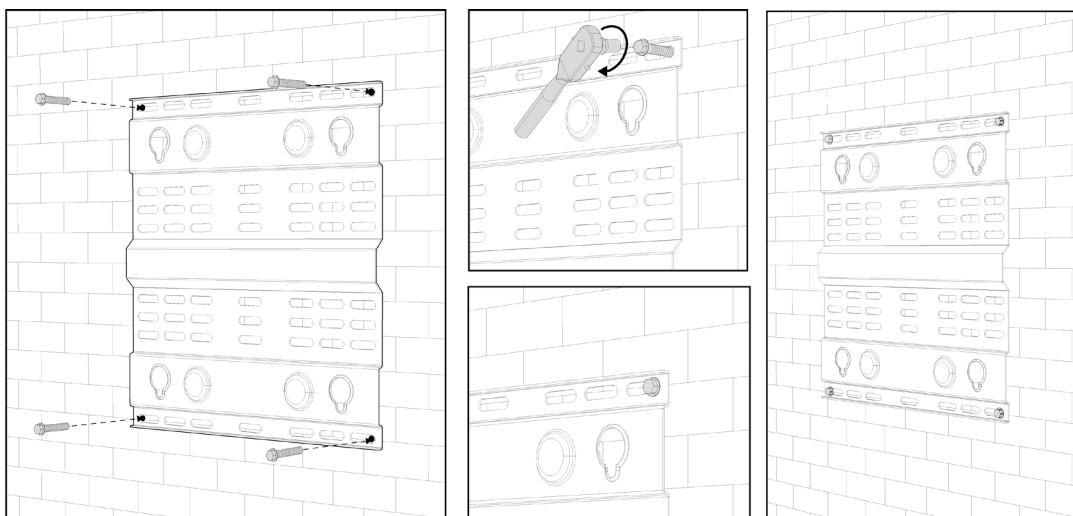

- e. Insert the four mounting columns on the back of the battery into the slide rail and slide them to the end, and then remove the handlebars.

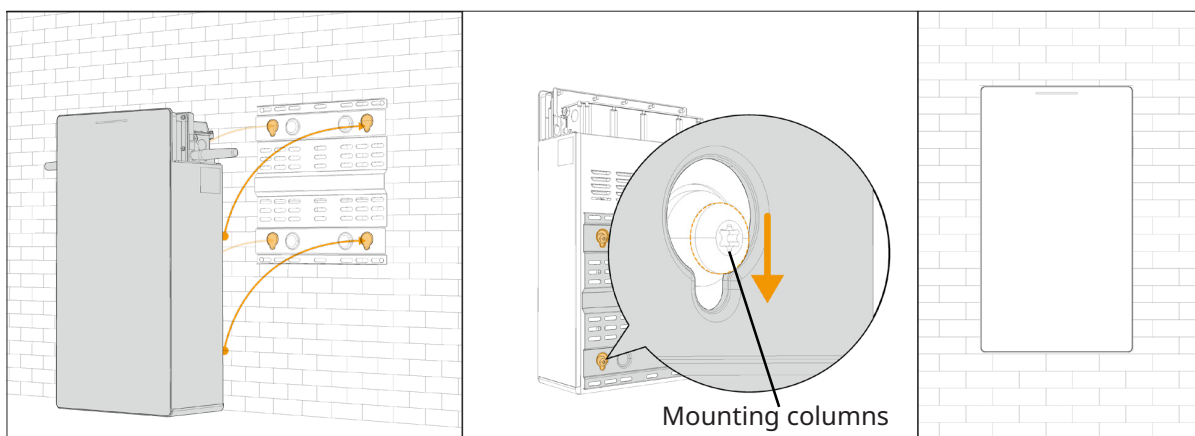

4.4 Remove the cover of the wiring cabinet

- a. Loosen the 13 screws and remove the cover of the wiring cabinet.

NOTE:

- Do not use the impact drivers and drills to tighten or loosen the screws.
- These screws are captive screws, do not attempt to unscrew them completely.

M-Battery User Manual

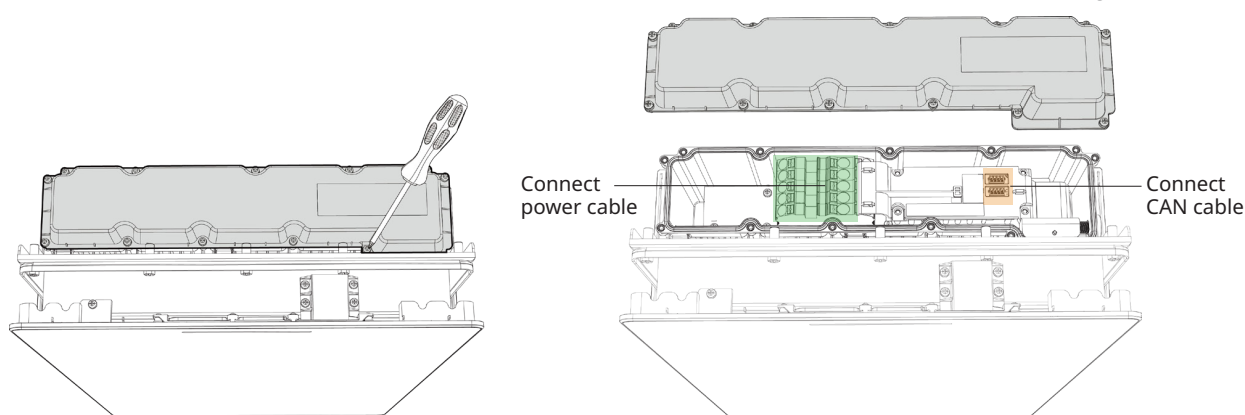

b. The details of the terminal are shown as below.

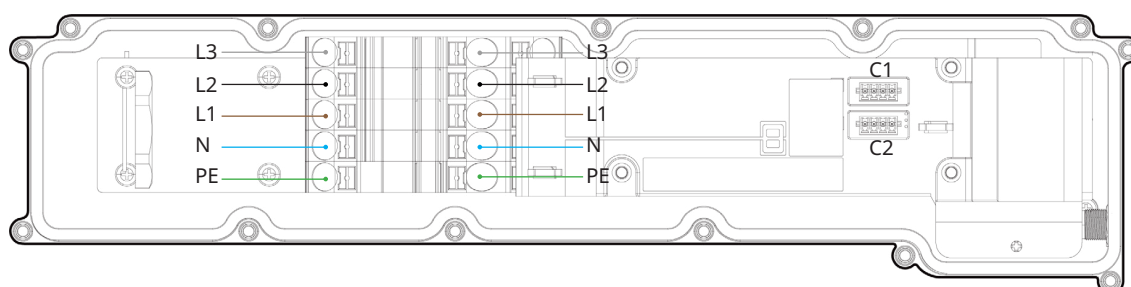

4.5 Remove the knockout

- Use the hammer and the screwdriver to remove the knockout. In the case of multiple batteries, remove the knockout on both sides.
- Mount the waterproof fittings on the holes.
- Tighten the lock nuts of the glands with a torque of 4–5 N·m and the sealing nuts with a torque of 7–7.5 N·m.

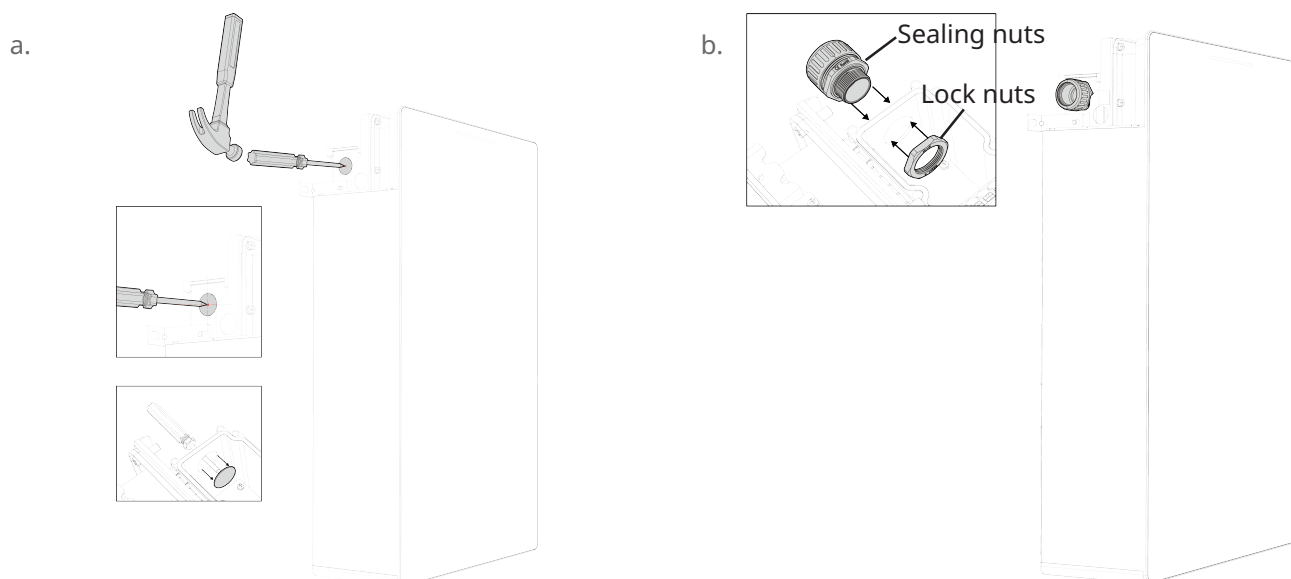

NOTE:

- The screwdriver should be aligned with the center of the knockout.

4.6 Wire the cables

NOTE:

- The cables must connect to the battery breaker and terminals in the combiner. The wiring is different for each model of the combiner. Please check the label inside the combiner for more information.
- Improperly connected L and N will damage the equipment.

4.6.1 Single battery scenario

Section A. Wire the power cable

- Connect the cables to the battery breaker and PE terminal in the combiner.
- Bring in the power cables from the combiner through the hole of the battery.
- Connect the cables to the power and PE terminal block in the battery.

Single-phase

— L — N — PE

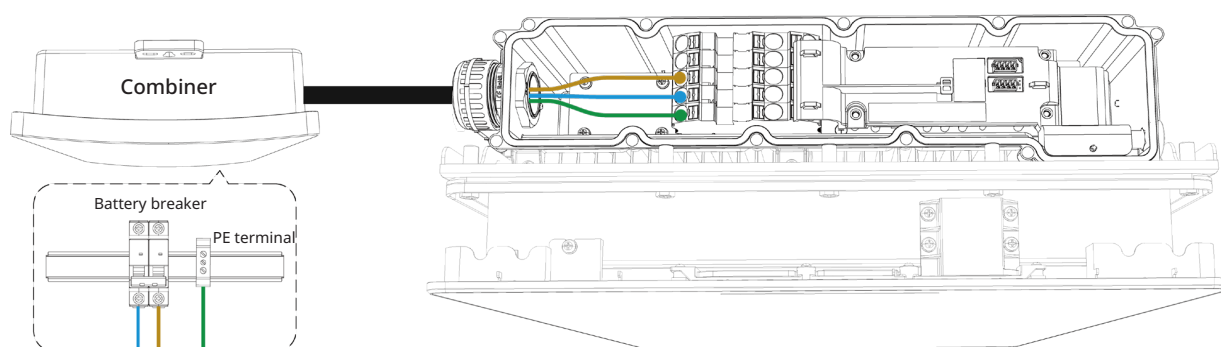

NOTE:

- For single-phase systems, the plug-in bridge must be fully inserted as shown.
- After the installation, confirm that the plug-in bridge is not loose.

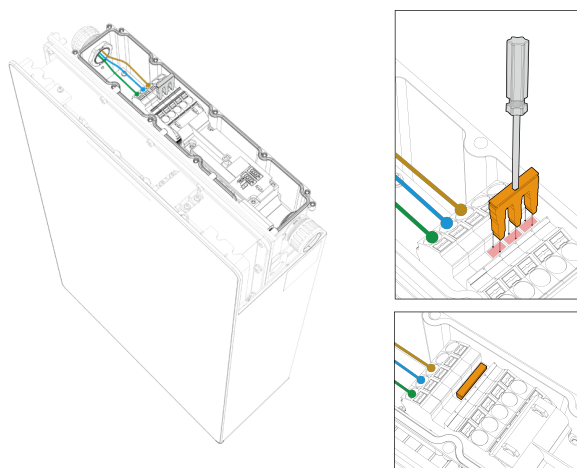

Three-phase

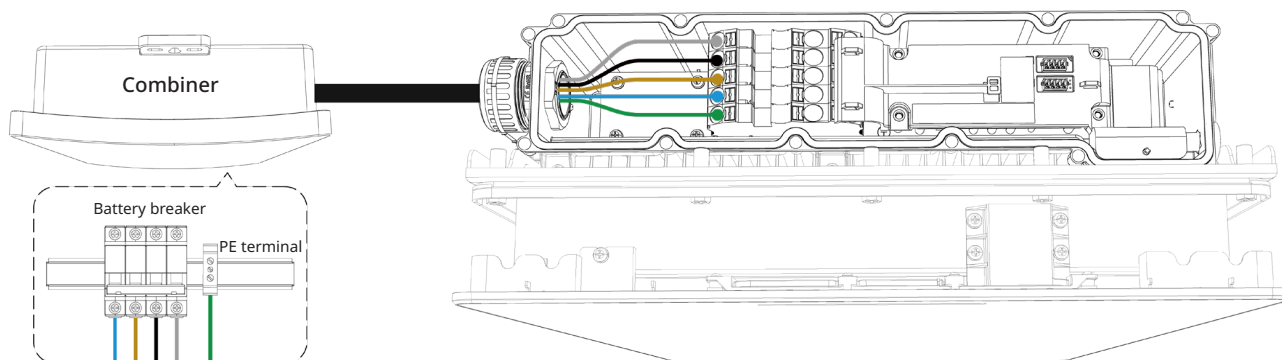

Section B. Wire the CAN communication cable

- Connect the CAN cable to the communication terminal in the combiner as the label in the combiner.
- Bring in the CAN communication cables from the combiner through the hole of the battery.
- Remove the resistor on the C1 terminal. Please do not perform any operations on the C2 terminal and resistor.

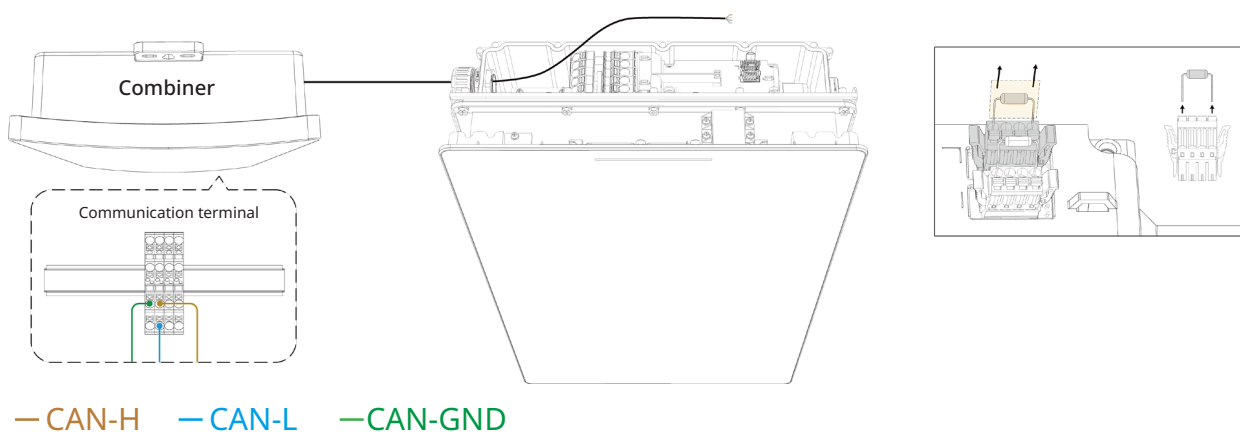

- Connect the cable to the C1 terminal as below.

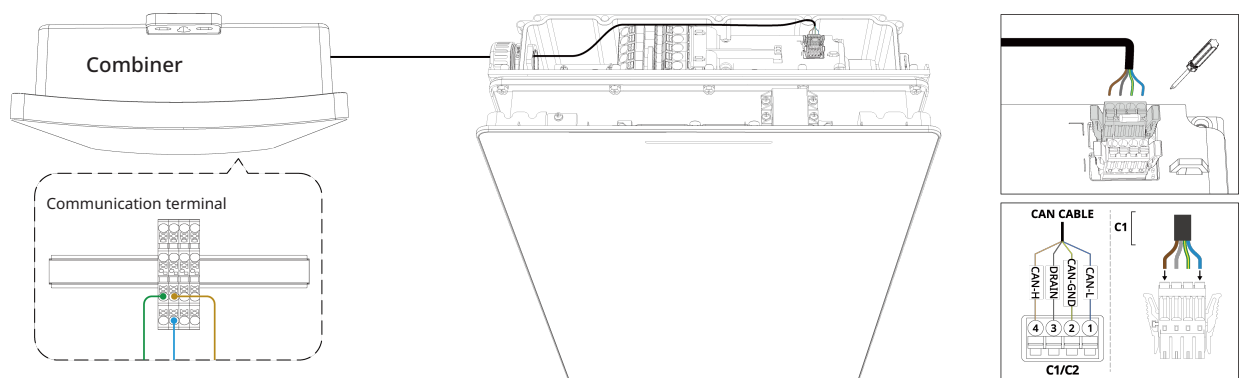

e. Arrange the cables and check the wiring is correct.

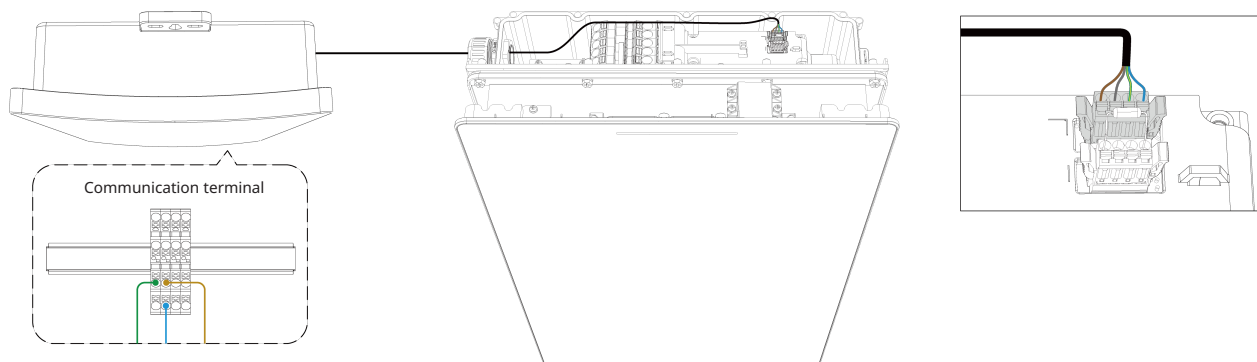

4.6.2 Multiple batteries scenario

Section A. Wire the power cable

- Connect the cables to the battery breaker and PE terminal in the combiner.
- Bring in the power cables from the combiner through the hole of the battery.
- Connect the cables to the power and PE terminal block in the battery.

Single-phase

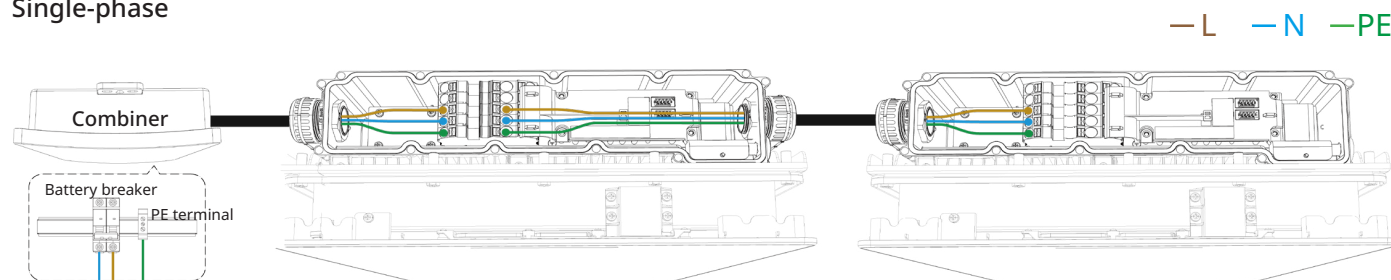

NOTE:

- For single-phase systems, the plug-in bridge must be fully inserted as shown.
- After the installation, confirm that the plug-in bridge is not loose.

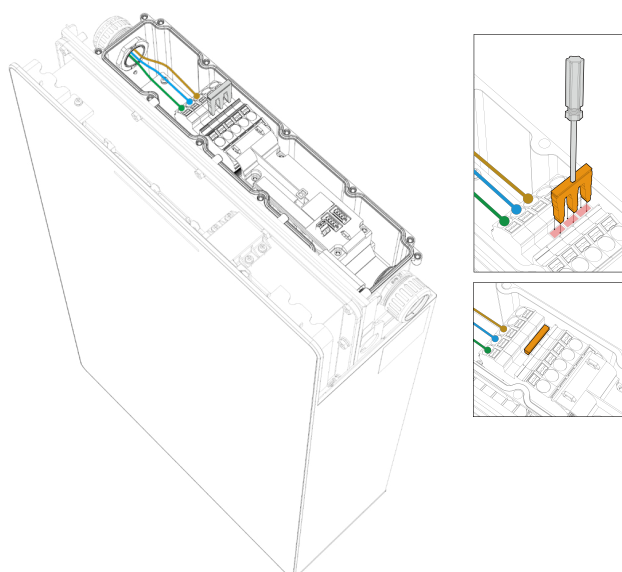

Three-phase

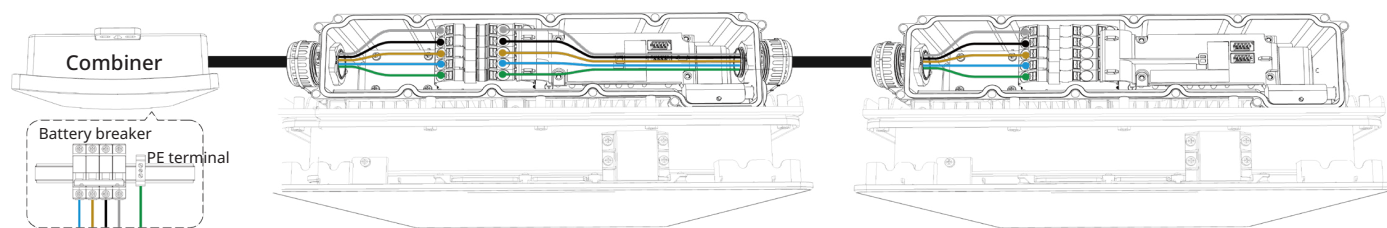

Section B. Wire the CAN communication cable

- Connect the CAN cable to the communication terminal in the combiner.
- Bring in the CAN communication cables from the combiner and 1.5 m CAN cable through the hole of the battery.

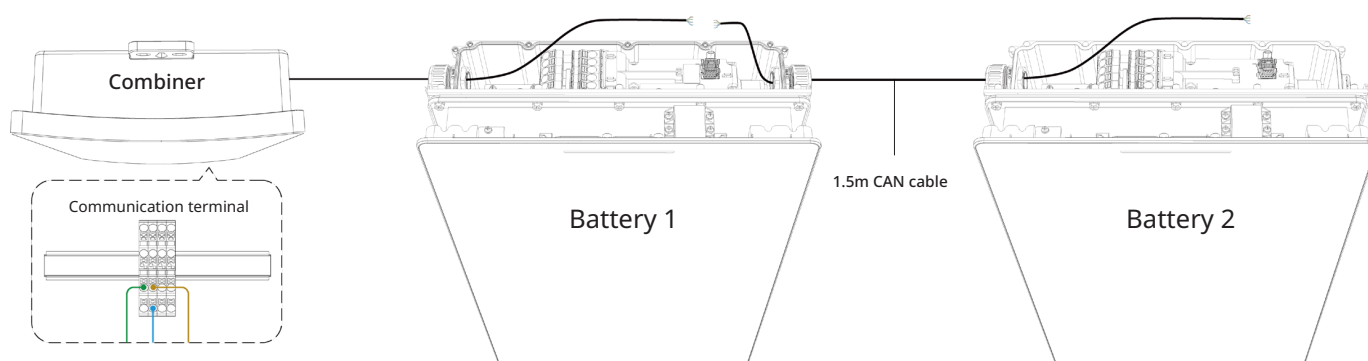

— CAN-H — CAN-L — CAN-GND

- For the battery 1, remove the resistor on the C1 and C2 terminal, and then connect the cable to the C1 and C2 terminal as below.

C1

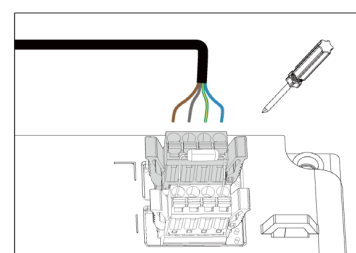
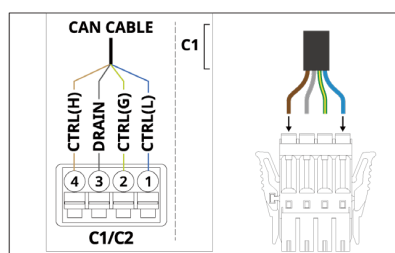
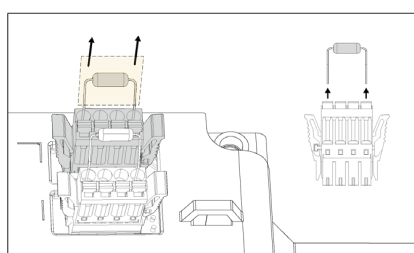

C2

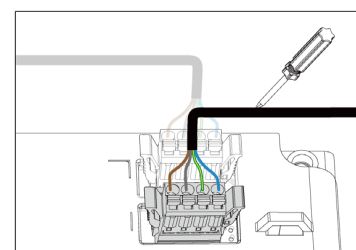
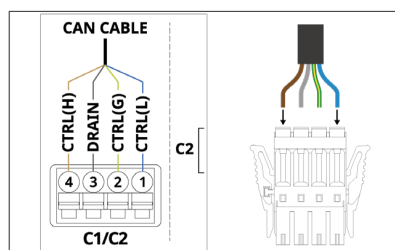
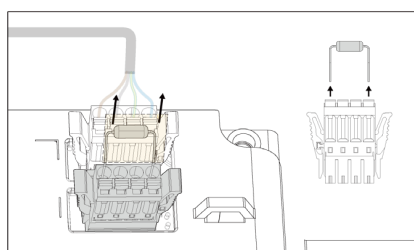

- d. For the battery 2, remove the resistor on the C1 terminal, and then connect the cable to the C1 terminal as below. Please do not perform any operations on the C2 terminal and resistor.

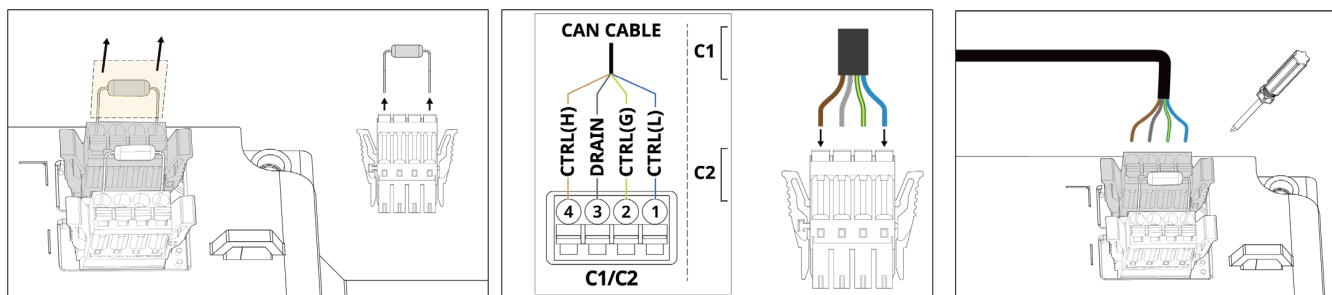

- e. Arrange the cables and check the wiring is correct.

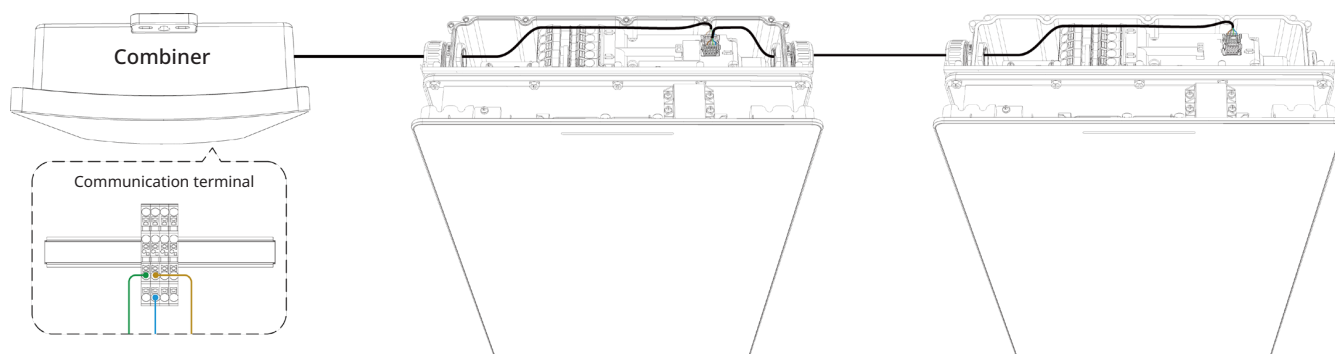

4.7 Close the cover of the wiring cabinet

- a. Re-install the cover. Follow the sequence (from 1 to 13) as shown in the figure to tighten the 13 screws.

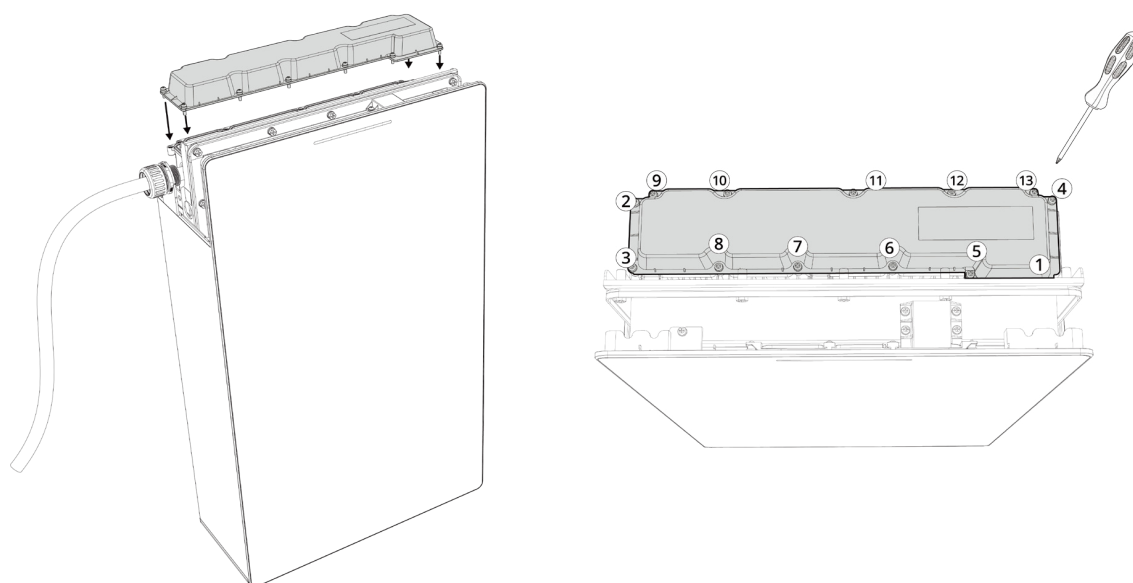

NOTE:

- Do not use the impact drivers and drills to tighten or loosen the screws.

4.8 Remove the knockout of the upper cover

- a. Wear the protective gloves and remove the knockout of the upper cover.

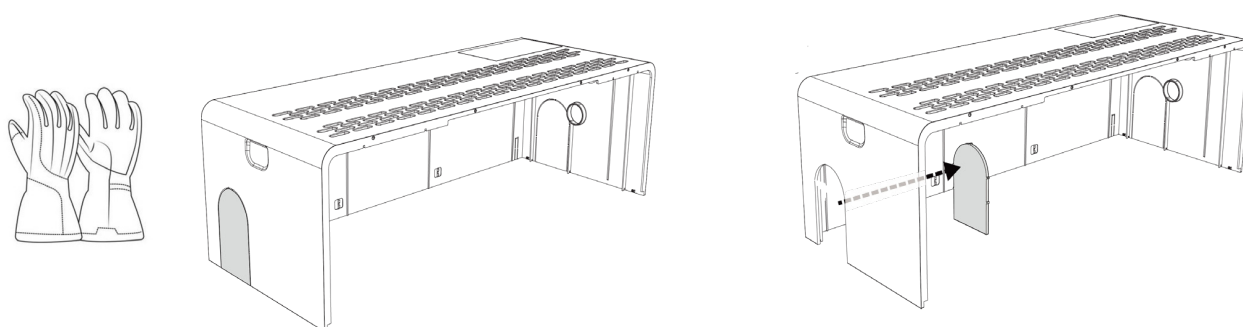

NOTE:

- Please remove the knockout according to the wiring conditions.

4.9 Close the upper cover

- a. Close the upper cover.

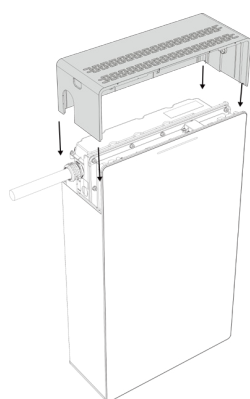

NOTE:

- For floor mounting, remove the mounting buckles of the upper cover.

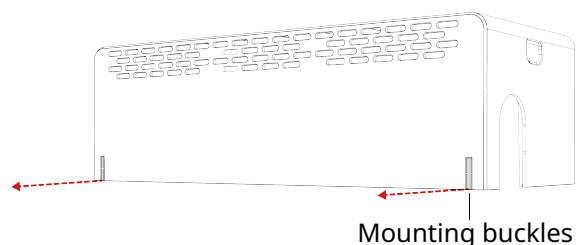

4.10 Power on the system

- a. Use the multimeter to measure the voltage between the N pole and L1 pole (or L2 pole, L3 pole). The voltage value should be approximately the nominal phase voltage, e.g. 220 V, 230 V and 240 V.
- b. Switch on the battery breaker in the combiner and power on the system.

4.11 Activate the system

- a. Log in to the ATMOZEN APP on your mobile phone and follow the deployment guide in the app to activate the system.
- b. After the system is activated, the SOC status LED will be solid blue.

Operation and Maintenance

5.1 Battery Working Mode

The battery operating mode supports Self-consumption and Time of Use. The settings are shown in the figure.

- a. Tap Site Settings of the site.
- b. Select Battery Working Mode to setting.

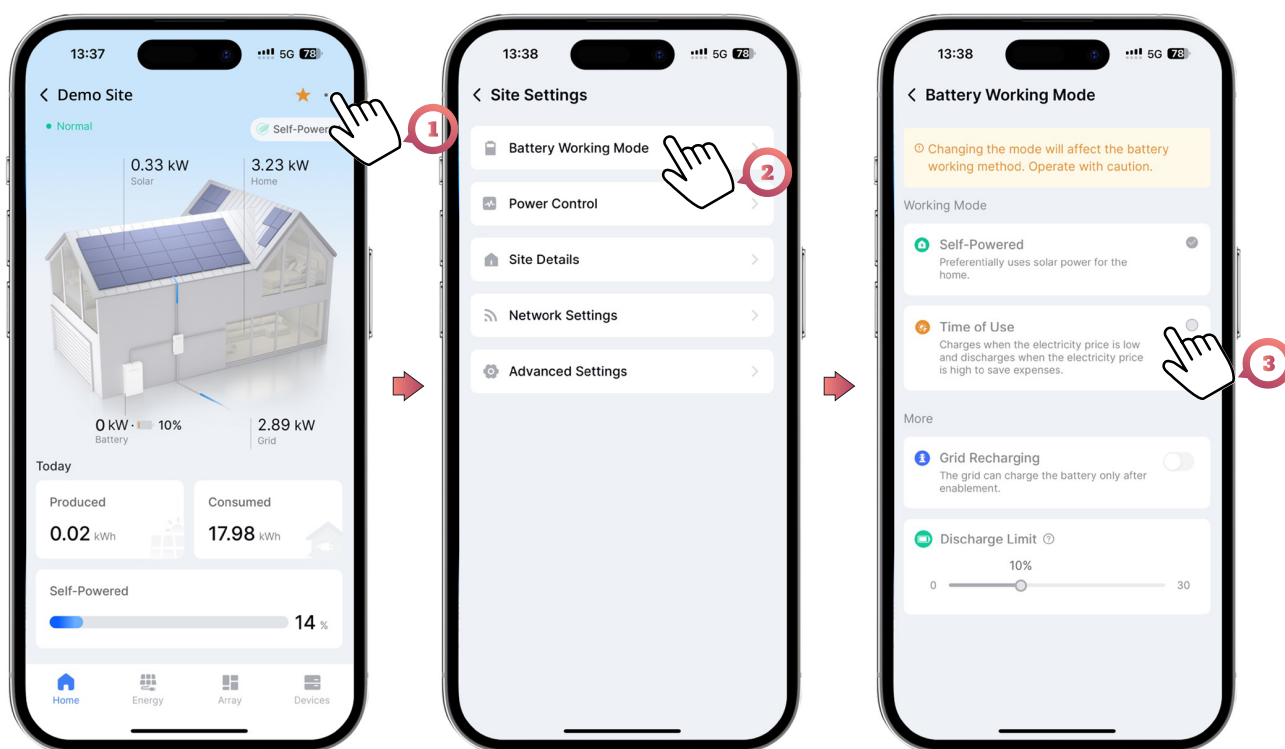



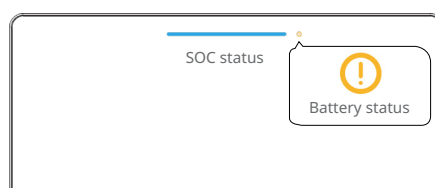

Troubleshooting

6.1 LED Indicator Description

The M-battery has two types of LEDs and the following table describes their status.



Function	Colour		Description
SOC status	Solid blue		Remaining battery energy percentage
Battery status	Quick flash		Abnormal working condition
	Solid red		The battery has an internal fault
	Dim		Normal operation

6.2 Check the alert Codes

The device error codes can be viewed through the following steps in the Atmozen app:

- Tap Status of the site.
- Select the faulty device to check the details.

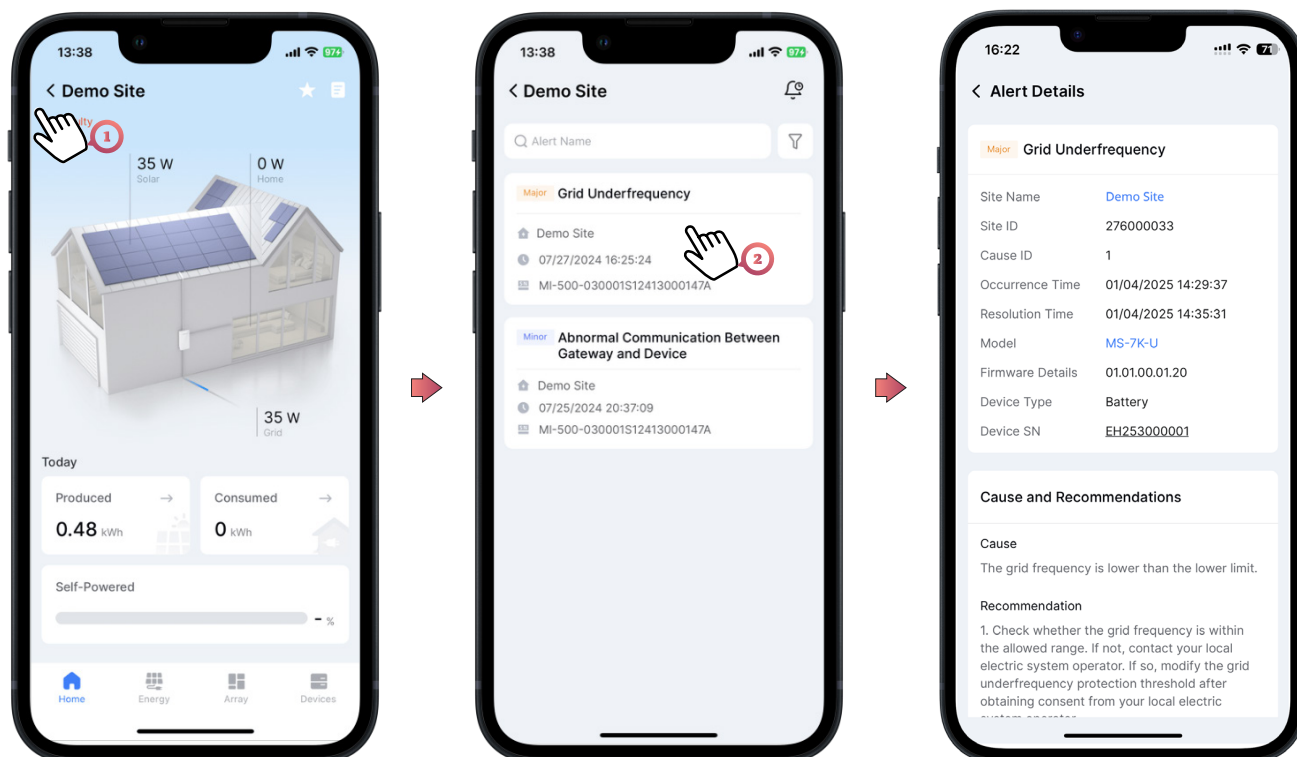

NOTE:

- The alert code check can be performed only after the system has been activated via the Atmozen app.
- Alert codes can be checked only when the site status is 'Faulty' or 'Offline'.

6.3 Alert Codes List

Code	Issue	Reason	Solution
2	Grid Power Outage	Grid power outage occurred.	<ol style="list-style-type: none"> 1. Check whether the grid is normally powered. 2. Check whether the alternating current cable or breaker is disconnected.
3	Grid Undervoltage	The grid voltage is lower than the lower limit.	<ol style="list-style-type: none"> 1. Check whether the grid voltage is within the allowed range. If not, contact your local electric system operator. If so, modify the grid undervoltage protection threshold after obtaining consent from your local electric system operator. 2. If the fault persists, check whether the alternating current breaker and cable are connected properly.
4	Grid Overvoltage	The grid voltage is higher than the upper limit.	<ol style="list-style-type: none"> 1. Check whether the grid voltage is within the allowed range. If not, contact your local electric system operator. If so, modify the grid overvoltage protection threshold after obtaining consent from your local electric system operator. 2. If the fault persists, check whether the alternating current breaker and cable are connected properly, or whether the cable complies with the recommended specifications.
5	Grid Underfrequency	The grid frequency is lower than the lower limit.	<ol style="list-style-type: none"> 1. Check whether the grid frequency is within the allowed range. If not, contact your local electric system operator. If so, modify the grid underfrequency protection threshold after obtaining consent from your local electric system operator.
6	Grid Overfrequency	The grid frequency is higher than the upper limit.	<ol style="list-style-type: none"> 1. Check whether the grid frequency is within the allowed range. If not, contact your local electric system operator. If so, modify the grid overfrequency protection threshold after obtaining consent from your local electric system operator.

Code	Issue	Reason	Solution
7	High Output Direct Current Component	<p>The output direct current component is higher than the upper limit.</p> <ol style="list-style-type: none"> 1. Abnormal phase in the single-phase system. 2. Phase loss in the three-phase system. 3. Reversed phase sequence in the three-phase system. 4. Short circuit in the three-phase system. 	<ol style="list-style-type: none"> 1. The device automatically monitors external working conditions in real time and returns to normal after the fault is resolved. 2. If the fault occurs frequently, contact your distributor or Customer Service. <ol style="list-style-type: none"> 1. For single-phase battery, check for a short circuit in the AC input. 2. For three-phase battery, check for phase loss, reversed phase sequence, or short circuits in the AC wiring. 3. If the alert persists, contact your distributor or Customer Service.
13	Distribution error occurred.	<p>The single-/three-phase wiring in the battery is inconsistent with the single-/three-phase configuration in the combiner.</p>	<ol style="list-style-type: none"> 1. Please check whether the AC distribution wiring of the battery is consistent with the single-/three-phase configuration in the combiner. 2. If the alert persists, contact your distributor or Customer Service.
18	High Output DC Voltage Component	<p>The output DC voltage component is higher than the upper limit.</p>	<ol style="list-style-type: none"> 1. The device automatically monitors external working conditions in real time and returns to normal after the fault is resolved. 2. If the fault occurs frequently, contact your distributor or Customer Service.
50	Battery Overvoltage	<p>The total battery voltage or battery cell voltage exceeds the alert threshold.</p>	<ol style="list-style-type: none"> 1. In the app, shut down the battery and then power it on again; 2. Reset the system in the app; 3. If the battery is connected to the grid, disconnect the AC input, wait for the battery indicator to go out, and then restore the AC input; 4. If the alert persists, contact your distributor or Customer Service.

Code	Issue	Reason	Solution
51	Battery Undervoltage	The total battery voltage is below the alert threshold.	<ol style="list-style-type: none"> 1. If the battery is connected to the grid, disconnect the AC input, wait for the battery indicator to go out, and then restore the AC input; 2. Reset the system in the app; 3. If the alert persists, contact your distributor or Customer Service.
		The voltage of a battery cell is too low.	<ol style="list-style-type: none"> 1. If the battery is connected to the grid, disconnect the AC input, wait for the battery indicator to go out, and then restore the AC input; 2. Reset the system in the app; 3. If the alert persists, contact your distributor or Customer Service.
52	Large Battery Cell Voltage Difference	The voltage difference between battery cells exceeds the alert threshold.	<ol style="list-style-type: none"> 1. If the battery is connected to the grid, disconnect the AC input, wait for the battery indicator to go out, and then restore the AC input. 2. Reset the system in the app. 3. If the alert persists, contact your distributor or Customer Service.
53	Battery Overtemperature	<ol style="list-style-type: none"> 1. The battery temperature exceeds the alert threshold 2. The ambient temperature is too high. 3. The fan is not working normally. 	<ol style="list-style-type: none"> 1. Wait for a while and check if the alert disappears automatically. 2. If the alert is reported frequently, please ensure that the working conditions of the device are within the allowed range. 3. If the alert persists, contact your distributor or Customer Service.
54	Low Battery Temperature	<ol style="list-style-type: none"> 1. The battery temperature is below the alert threshold. 2. The ambient temperature is too low. 3. The heating system is not working normally. 	<ol style="list-style-type: none"> 1. Please ensure that the working conditions of the device are within the allowed range. 2. If the alert persists, contact your distributor or Customer Service.
55	Large Battery Cell Temperature Difference	<ol style="list-style-type: none"> 1. The temperature difference between battery cells exceeds the alert threshold. 2. The fan is not working normally. 	<ol style="list-style-type: none"> 1. Shut down the battery and then power it on again. 2. Reset the system. 3. If the alert is reported frequently, contact your distributor or Customer Service.
56	Battery Overcurrent	The battery current exceeds the alert threshold.	<ol style="list-style-type: none"> 1. Wait for a while and check if the alert disappears automatically. 2. If the alert is reported frequently, reset the system in the app. 3. If the alert persists, contact your distributor or Customer Service.

Code	Issue	Reason	Solution
57	Low Battery SOH	The battery health metric is below the alert threshold.	<ol style="list-style-type: none"> 1. The battery lifespan has reached its end. Please stop using the battery. 2. Please follow the legal regulations in your country/region and contact local battery recycling services for disposal.
58	Battery Life Terminated	The battery lifespan has reached its end.	<ol style="list-style-type: none"> 1. The battery lifespan has reached its end. Please stop using the battery. 2. Please follow the legal regulations in your country/region and contact local battery recycling services for disposal.
59	Battery Micro-Short Circuit	The battery micro-short circuit fault occurred.	<ol style="list-style-type: none"> 1. Please contact your distributor or Customer Service.
60	Battery Thermal Runaway	The battery thermal runaway fault occurred.	<ol style="list-style-type: none"> 1. Please immediately disconnect the battery AC input and stop using the battery. 2. Please contact your distributor or Customer Service.
		The internal circuit fault protection of the battery is triggered.	<ol style="list-style-type: none"> 1. In the app, shut down the battery and then power it on again; 2. Reset the system in the app; 3. If the battery is connected to the grid, disconnect the AC input, wait for the battery indicator to go out, and then restore the AC input; 4. If the alert persists, contact your distributor or Customer Service.
62	Internal Device Error	The internal circuit of the battery failed.	<ol style="list-style-type: none"> 1. In the app, shut down the battery and then power it on again; 2. Reset the system in the app; 3. If the battery is connected to the grid, disconnect the AC input, wait for the battery indicator to go out, and then restore the AC input; 4. If the alert persists, contact your distributor or Customer Service.

Code	Issue	Reason	Solution
63	Abnormal Communication Between Battery and Gateway	<ol style="list-style-type: none"> 1. The device is shut down. 2. The CAN bus cable between the device and the gateway is abnormal. 	<ol style="list-style-type: none"> 1. Please ensure that the CAN bus cable between the gateway and battery module is reliably connected. 2. Reset the system. 3. If the alert persists, contact your distributor or Customer Service.
64	Active Device Protection	The operating environment of the battery is abnormal.	<ol style="list-style-type: none"> 1. The device automatically monitors external working conditions and returns to normal after the fault is resolved. 2. If the alert is reported frequently, contact your distributor or Customer Service.

Technical Data

7.1 M-Battery Data Sheet

Items	Unit	MS-7K-U
Electrical Parameters		
Max. continuous output power	kVA	4.5
Max. output power	kVA	5
Max. continuous input power	kVA	3.75
Nominal voltage	V _{a.c.}	1/N/PE ~ 220, 1/N/PE ~ 230 3/N/PE ~ 220/380, 3/N/PE ~ 230/400
Operating voltage range (L to N)	V _{a.c.}	176 - 276
Nominal frequency	Hz	50 / 60
Frequency range	Hz	45-55 @50 Hz, 55-65 @60 Hz
Max. input current	A	17.05 @ 220 V _{a.c.} , 5.70 @ 380 V _{a.c.} 16.30 @ 230 V _{a.c.} , 5.41 @ 400 V _{a.c.}
Max. output current	A	22.73 @ 220 V _{a.c.} , 7.58 @ 380 V _{a.c.} 21.74 @ 230 V _{a.c.} , 7.25 @ 400 V _{a.c.}
Power factor (adjustable)		0.8 leading...0.8 lagging
AC round-trip efficiency	%	90
THDi	%	<3
Battery		
Rated battery energy	kWh	7
Nominal battery capacity	Ah	280
Nominal DC voltage	V	25.6
Max. DC voltage	V	28.8
Chemistry		Lithium iron phosphate (LFP)
Number of cycles		10,000
DC round-trip efficiency	%	96

M-Battery User Manual

Items	Unit	MS-7K-U
Mechanical data		
Dimensions (without bracket)	mm	830 × 480 × 195 (H x W x D)
Lifting weight (without bracket)	kg	73.5
Mounting		Floor or wall mount
Ambient operating temperature range	°C	-20 to 55
Optimum operating temperature range	°C	0 to 30
Storage temperature	°C	-20 to 55
Protection class		I
Ingress Rating		IP66
Cooling		Intelligent air cooling
Operating Humidity (RH)	%	4 to 100, condensing
Altitude	m	Up to 3,000
Pollution Rating		PD3
Operation Noise	dB	< 35
Protection		
AC port overvoltage class		III
AC surge protection		TYPE II
Galvanic Isolation		YES
Insulation resistance monitor		YES
Features and compliance		
Indicator		LEDs for SOC & Status
Communication		CAN
Services ^a		Self-consumption, TOU, Grid ancillary services
Cloud Service		ATMOCE Cloud & ATMOZEN APP
Compliance		IEC 62619, ISO 13849, IEC 61000-6-1, IEC 61000-6-3, IEC 63056, IEC 62477-1, VDE- AR-E 2510-50

a. Work together with ATMOCE Gateway

Appendix 1: Terms and Abbreviations

AC	Alternating current
APP	Application
CAT 6	Category 6
DC	Direct current
DI	Digital input
DO	Digital output
EMC	Electromagnetic Compatibility
ETH	Ethernet
MPPT	Maximum power point tracking
PE	Protective earthing
PV	Photovoltaic
RH	Relative humidity
SN	Serial number
WEEE	Waste electrical and electronic equipment

Contact Details

Company: ATMOCE Holding B.V.
Address: Rokin 92-96, 1012 KZ Amsterdam, the Netherlands
Email: info@atmoce.com
Telephone: +31 20 241 6207

ATMOCE

Copyright © Atmoce Holding B.V. 2025. All rights reserved.

No parts of this document may be reproduced or transmitted in any form or by any means without the prior written consent of Atmoce Holding B.V.

Trademark Notice

ATMOCE Atmoce logo is trademark or registered trademark of Atmoce Holding B.V.

Other trademarks, product names, services, and company names mentioned are the property of their respective owners.

General Disclaimer

The information in this document may contain predictive statements, including, without limitation, statements regarding future financial and operational results, future product portfolios, new technologies, etc. There are a number of factors that could cause actual results and developments to differ materially from those expressed or implied in the predictive statements. Therefore, such information is provided for reference purposes only and constitutes neither an offer nor an acceptance. Atmoce may change the information at any time without notice.